



**singing
rock®**

C
L
I
M
B
I
N
G

WORKBOOK 2024/25 | 



SINGING ROCK COMPANY

We are climbers who work for climbers

We put not only our experience, but also our enthusiasm into our climbing equipment.
We proudly do it in Czechia.

We are here for those who want to see the vertical world as it is, without pretence and unrealistic ballast.
We do not embellish or hide anything.
We respect the purity of purity of climbing at height and that's how we approach our products.



read more
about our
company



We offer solutions

We always look for an ideal and complex solution of a product, situation or communication, so that our customers are satisfied.



SINGING ROCK VALUES

We are climbers who work for climbers

Pure experience

It is a part of our products and manner of communication.
We share it with every interaction.

Climbers for climbers

We understand the world of our customers and we talk to them accordingly.
We make our climbing equipment as if we were making it for ourselves.

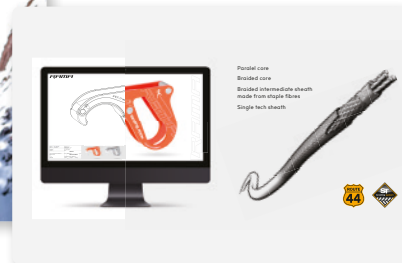

Functionality

The value of real climbers who at height who don't need fancy and glitz. They are self-confident and rely on the equipment they use.

MISSION

We make products for your vertical world.

We bring simplicity, authenticity and fair behaviour to climbing and working at heights.



read more about our history

MILESTONES

From **TUCAN** to **SINGING ROCK**. From "Tatman" to the "Arrow". From one sewing machine and 40 m2 of a workshop at home to three manufacturing plants and more than 170 employees. These and more are the milestones of SINGING ROCK.

1992

Foundation of SINGING ROCK by two professional climbers

1995

SINGING ROCK enters the work at height segment, complementing its outdoor climbing business

2000

QMS certification according to ISO 9001 (and Art. II B of Council Directive 89/686/EEC)

Investment into own factory in Poniklá

2001



Redesign corporate image

Launch of in-house developed dynamic and static ropes

2003

Launch of own designed line of carabiners and other hardware

2005



Introduction of POLYGON brand and opening of the first center in Poniklá

2008



Acquisition of SINGING ROCK by ARX Equity Partners

2009

Merger with LANEX

Investment in a second training center in Kladno

Acquisition of new production space for textile production in Semily

2011



Acquisition of Raveltik, incorporating capabilities in the hardware segment and expanded coverage of the mountaineering and ice climbing segments

2013



POLYGON's training centers in Poniklá and Kladno become certified by IRATA

Spin-off from LANEX and reorganization as an independent entity

2015

ARX Private Equity Partners sold 100% share in SINGING ROCK to Mr. Rudolf Bochenek with a majority share and Rudolf Gregořica as minority partner

2017

Mr. Bochenek acquires shares of Mr. Gregořica and fully incorporates Singing Rock to BR Group holding

2019

Presentation of the Polygon Partner franchise system

QMS and certificates transfer from 89/686/EEC PPE Directive to 2016/425 PPE Regulation (EU)

2020

Refreshment of the brand visual

2022

30th Anniversary



PRODUCTION

PRODUCTION & QUALITY CONTROL

Although we are open to the world, the heart of SINGING ROCK beats in the Czech Republic. The headquarter, production, training and testing centre is located in Poniklá. Our textile production plant is situated in Semily. The production of metal products and components is placed in Sudkov. The Kladno training centre for work at height is just 20 min from Prague. Four locations in the Czech Republic, including three manufacturing plants and two training centres bring you the equipment and services for your vertical playground.



DISTRIBUTION

Singing Rock supplies products to more than 65 countries worldwide, through its network of distributors and agents. Thanks to them, you can find us wherever they understand climbing.



find your
SINGING ROCK
dealer

DISTRIBUTION

KNOWLEDGE & EXPERIENCE

Meeting minimum requirements is obvious. We go further by performing the tests to simulate all kind of usage as the basis for our further development. In our laboratory we can test our products on several testing machines f.e. a helmet testing machine or cycling hydraulic machine for fatigue tests of movable components and elastic webbings. Laboratory tests are, of course, complemented by testing and validation in the real environment.



RESEARCH & DEVELOPMENT

For more than 30 years, SINGING ROCK has built on its experience and knowledge in designing and manufacturing products for your vertical world. Developing our products requires expertise in a wide range of different materials and manufacturing technologies. Modern tools help our development team to create products to your and our satisfaction.

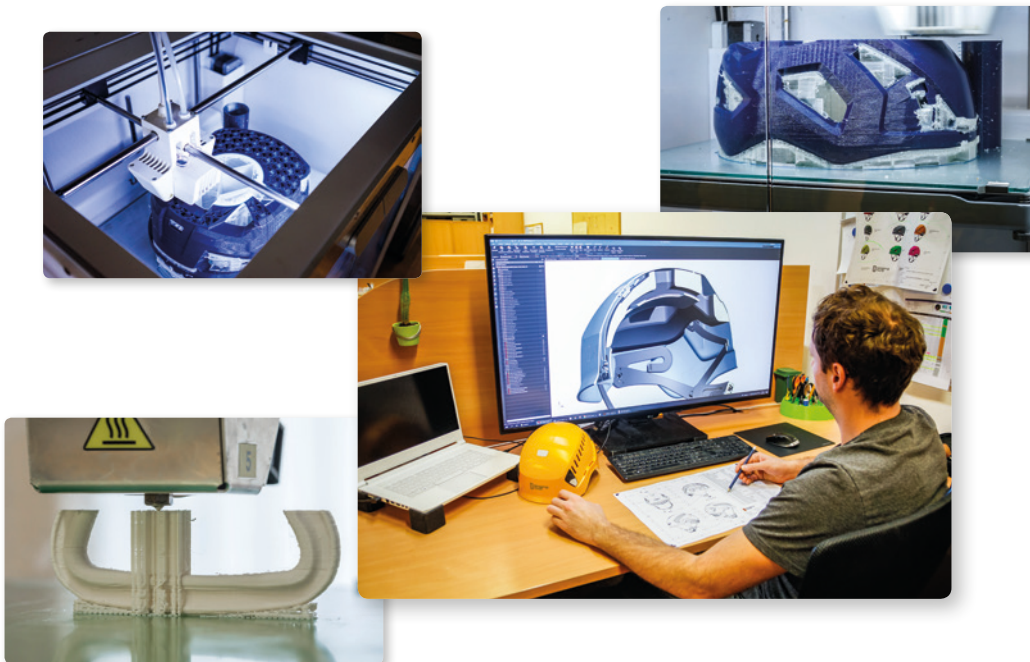

EFFICIENCY

EFFICIENCY

We run lean management system with horizontal organisation structure. Thanks to this structure we are able to react immediately and customize our products and service for your specific needs.

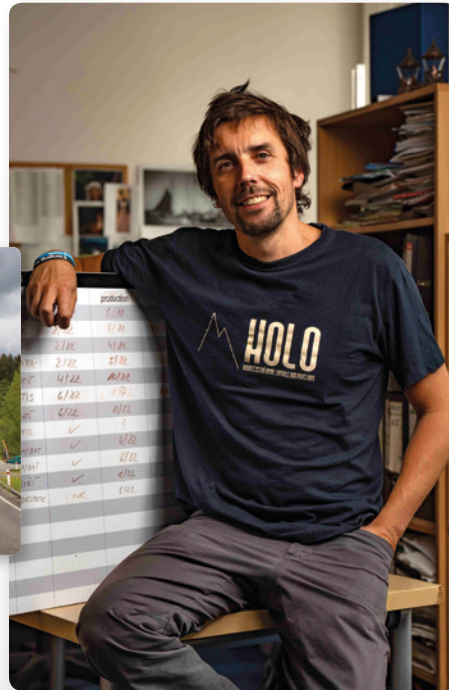

SUSTAINABILITY

We bear the responsibility to keep our planet green and to preserve its riches for our kids. Singing Rock is supporting by its membership in the European Outdoor Conservation Association environmental activities all around the world.



SUSTAINABILITY







HARNESSES

SIT, CHILDREN´S, FULLBODY,
CHEST, SKI TOURING,
VIA FERRATA, SPELEO,
CANYONING



ONYX

C5082ZH



High-end one-buckle climbing harness combining comfort and light weight. If you're looking for a lightweight harness for sport routes, Onyx is the right choice. Its strength is in its simplicity.

- one patented stainless steel Rock&Lock buckle ensures quick and comfortable adjustment at the waist
- flexible leg loops with elastic straps adjust themselves to fit you
- for quickdraws and other equipment, you have 4 shaped gear loops with textile braiding and a load capacity of 5 kg
- harness now offers 2 slots for auxiliary plastic PORTER carabiners, into which you can clip additional material
- in the back there is a haul loop with a load capacity of 10 kg
- well thought-out design of the waist belt and leg loops, which uses 2 webbings running along the edges of the padding,

distributes the load efficiently and ensures greater comfort when sitting or hanging in the harness

- EVA foam padding is covered on the inner side with a porous 3D fabric and on the upper side with high abrasion resistance fabric
- reinforced tie-in points are a matter of course
- durable belay loop has a width of 12 mm and a strength of 15 kN

Color: dull gold

Size: XS, S, M, L, XL

Weight: 335 g [size M] • 11.8 oz

€€ 1019 • EN 12277 • 

GARNET

C5084MX spruce blue
C5084HX mahogany brown



Do you want one harness for the crags, the gym or the mountains, simply for all your vertical activities? Then there's GARNET, a universal three-buckle climbing harness that you can wear from morning to evening and even at night.

- provides more comfort when climbing long multi-pitch routes
- optimizing body position while hanging or falling
- reduces the pressure on the upper body when having a large quantity of climbing material
- two large climbing gear loops with a load capacity of 15 kg with a possibility of adjusting the length of the loops
- two gear loops and one small gear loop

with a load capacity of 5 kg

Color: spruce blue, mahogany brown

Size: XS, S, M, L, XL, XXL

Weight: 375 g [size M] • 13.2 oz

€€ 1019 • EN 12277 • 



PEARL

C5083LX



All-round three-buckle climbing harness specially designed for women. You don't have to compromise, Pearl respects the specifics of the female figure and guarantees you comfort even when climbing all day.

- this harness is tailored to women's shapes – it has the specially shaped waist belt, extended belay loop and adjusted waist belt to leg loops size ratio
- you can easily adjust it using 3 patented stainless steel Rock&Lock buckles
- thanks to Rock&Lock buckles on the leg loops you can put the harness on without having to take your skis or crampons off
- for quickdraws and other equipment, you have 4 shaped gear loops with textile braiding and a load capacity of 5 kg
- harness now offers 2 slots for auxiliary plastic PORTER carabiners, into which you can clip additional material
- in the back there is a haul loop with a load capacity of 10 kg

- well thought-out design of the waist belt and leg loops, which uses 2 webbings running along the sides of the padding, distributes the load efficiently and ensures greater comfort when sitting or hanging in the harness
- EVA foam padding is covered on the inner side with a porous 3D fabric and on the upper side with high abrasion resistance fabric
- reinforced tie-in points are a matter of course
- durable belay loop has a width of 12 mm and a strength of 15 kN

Color: bath green
 Size: XS, S, M, L, XL
 Weight: 365 g [size M] • 12.9 oz
 CE 1019 • EN 12277 • UAA

SPINEL

C5085HX



A four-buckle climbing harness that you appreciate when you change your waist circumference often, for example when you change layers of clothing. Ideal companion for multi-pitches, mountaineering or winter climbing.

- 4 patented stainless steel Rock&Lock buckles allow you to adjust the harness precisely as you need it
- using two buckles on the waist belt you can easily centre it so the gear loops always stay in the optimal position
- thanks to Rock&Lock buckles on the leg loops you can put the harness on without having to take your skis or crampons off
- for quickdraws and other equipment, you have 4 shaped gear loops with textile braiding and a load capacity of 5 kg
- harness also offers slots for 2 auxiliary plastic PORTER carabiners, into which you can clip additional material
- in the back there is a haul loop with a load capacity of 10 kg

- well thought-out design of the waist belt and leg loops, which uses 2 webbings running along the sides of the padding, distributes the load efficiently and ensures greater comfort when sitting or hanging in the harness
- EVA foam padding is covered on the inner side with a porous 3D fabric and on the upper side with high abrasion resistance fabric
- reinforced tie-in points are a matter of course
- durable belay loop has a width of 12 mm and a strength of 15 kN

Color: mahogany brown
 Size: S, M/L, XL
 Weight: 405 g [size M/L] • 14.3 oz
 CE 1019 • EN 12277 • UAA



ARA

C5082ZH



Three-buckle children's climbing harness for small rock stars. With this harness, they'll be safe and comfortable at heights.

- ARA is for children who already have sufficiently developed hips for proper positioning and adjustment of the harness
- this harness is tailored to children's shapes – it has the specially shaped waist belt and adjusted waist belt to leg loops size ratio
- you can easily adjust the waist and leg loops with 3 patented stainless steel Rock&Lock buckles
- Rock&Lock buckles on the leg loops also allow the harness to be easily put on even with skis or crampons on the legs
- 2 shaped gear loops with textile braid and 5 kg load capacity are ready to carry quickdraws and other equipment
- in the back there is a haul loop with a load capacity of 10 kg
- well thought-out design of the waist belt and leg loops, which uses 2 webbings running along the sides of the padding,

distributes the load efficiently and ensures greater comfort when sitting or hanging in the harness

- EVA foam padding is covered on the inner side with a porous 3D fabric and on the upper side with high abrasion resistance fabric
- reinforced tie-in points are a matter of course
- durable belay loop has a width of 12 mm and a strength of 15 kN
- you can choose from two sizes

C5086LX01 – size K1
C5086LX02 – size K2

Color: bath green
Size: K1 and K2
Weight: 283 g [size K2] • 10 oz
€ 1019 • EN 12277 • 





SPORTS HARNESS FEATURES

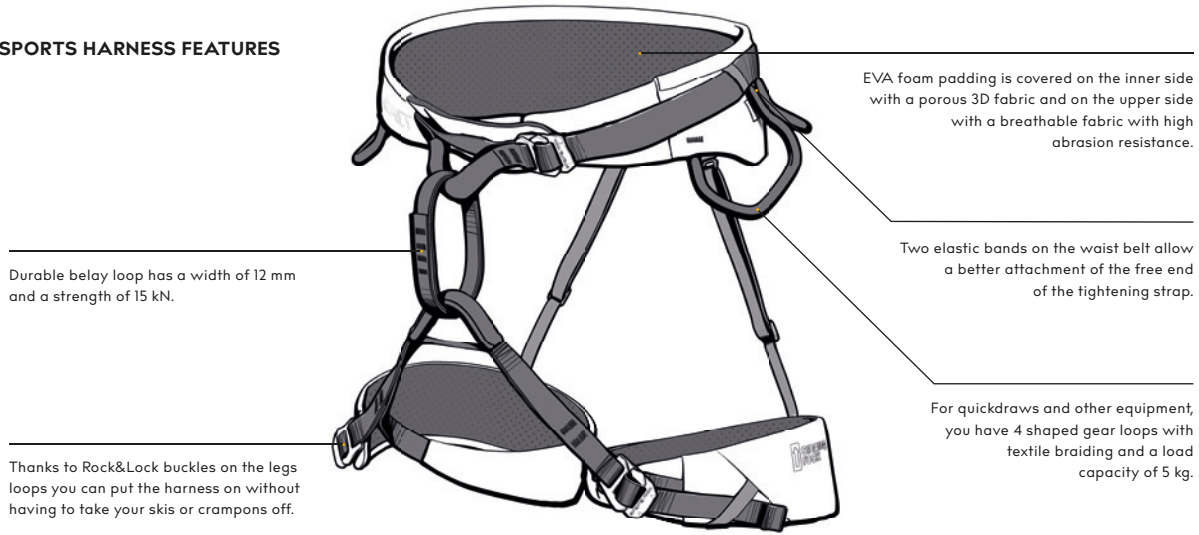

Durable belay loop has a width of 12 mm and a strength of 15 kN.

Thanks to Rock&Lock buckles on the legs loops you can put the harness on without having to take your skis or crampons off.

EVA foam padding is covered on the inner side with a porous 3D fabric and on the upper side with a breathable fabric with high abrasion resistance.

Two elastic bands on the waist belt allow a better attachment of the free end of the tightening strap.

For quickdraws and other equipment, you have 4 shaped gear loops with textile braiding and a load capacity of 5 kg.



ROCK&LOCK

patented smart buckle system

Easy to lock and open: Only small effort of your fingers is needed to lock and open.

- Fast lace-through: Make the loop, put it through the buckle frame, hook the loop on cross bar and tighten. It is easy as that.
- Smart function: Rock&Lock allows you to put on your harness very quickly.
- Double safety: Webbing cannot slip through Rock&Lock due to safety loop at the end. Spontaneous opening of Rock&Lock is virtually impossible.
- Lightweight and extra strong.
- Excellent function in all-season conditions: Function guaranteed even when webbing is wet or frozen.



Power distribution at the waist belt and leg loops:

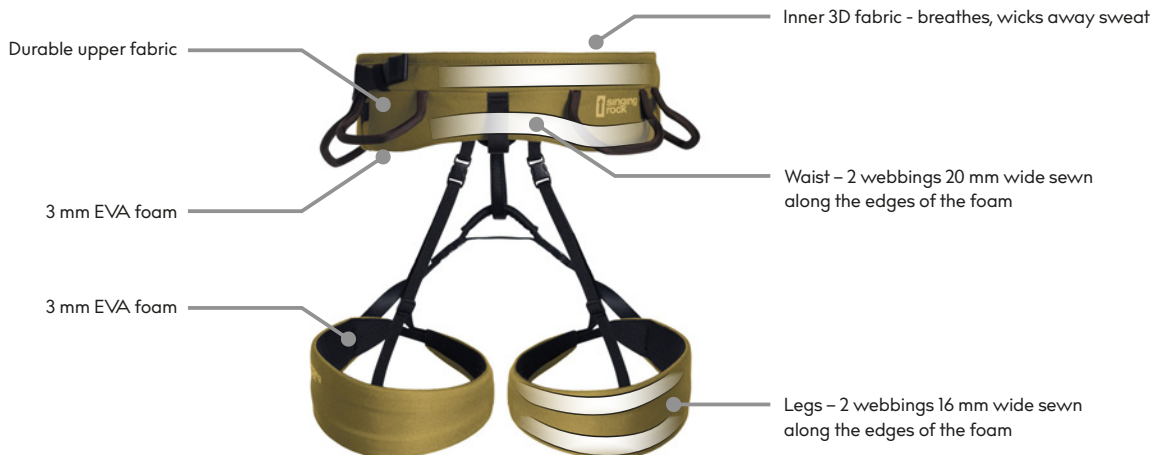

Durable upper fabric

3 mm EVA foam

3 mm EVA foam

Inner 3D fabric - breathes, wicks away sweat

Waist - 2 webbings 20 mm wide sewn along the edges of the foam

Legs - 2 webbings 16 mm wide sewn along the edges of the foam



RECOMMENDED USE OF SINGING ROCK HARNESSES

PRODUCT NAME	ADJUSTABLE LEG LOOPS	BUCKLES	WEIGHT (g/oz) size M	SPORT CLIMBING	GYM CLIMBING, RENTALS	TRAD CLIMBING, ALPINE	GLACIER TRAVEL, CLASSIC MOUNTAINEERING	TECHNICAL MOUNTAINEERING, ICE CLIMBING	VIA FERRATA	SKITOURING, EXPEDITIONS	ROPE COURSES	CANYONING, SPELEO
ROCKET	✗	1	250 8,8	++++	++++	++	++	++	+++	+	+	✗
ONYX	✗	1	335 11,8	++++	++++	+++	++	++	+++	+	+	✗
PEARL	✓	3	365 12,9	++++	+++	+++	++	++	++	+	+	✗
GARNET	✓	3	380 13,4	+++	+++	+++	++	++++	++	+	+	✗
SPINEL	✓	4	415 14,29	+++	++	++++	++	++++	++	+	+	✗
VERSA II	✓	3	410 14,5	++	++++	++	++	++	++	+	++++	✗
ROB	✗	1	335 11,8	+++	++++	++	++	++	++	+	+	✗
RAY	✓	3	385 13,6	+++	++++	++	++	++	++	+	+	✗
DOME	✓	4	630 22,2	+	+	++++	++	+++	+	+	+	✗
ARA	✓	3	283 10	++++	++++	++	++	++	+++	+	++	✗
TOP	✓	3	366 12,9	+	++	+	+++	+	++++	+++	++++	✗
TOP PADDED	✓	3	402 14,1	+	++	+	+++	+	++++	+++	++++	✗
TOP RENTAL	✓	3	395 13,9	+	++	+	++	+	++++	+++	++++	✗
SERAC	✓	2	96 33,9	+	+	+	+++	+	+++	++++	✗	✗
CANYON XP	✓	3	620 21,9	✗	✗	✗	✗	✗	✗	✗	✗	++++
TOP CANYON	✓	3	502 17,6	✗	✗	✗	✗	✗	✗	✗	✗	++++
DIGGER LIGHT	✓	3	550 19,4	✗	✗	✗	✗	✗	✗	✗	✗	++++
ZAZA	✓	3	338 11,9	++	++++	+	+	+	++++	+	++++	✗
TARZAN	✓	8	1530 54	✗	✗	✗	✗	✗	✗	✗	✗	++++
TARZAN ECONOMIC	✓	7	1050 37	✗	+	✗	✗	✗	✗	✗	✗	++++
COMPLETE	✓	4	520 18,3	✗	+	✗	+	✗	++	✗	++++	✗
ROPEDANCER II	✓	6	1195 42,2	✗	✗	✗	✗	✗	✗	✗	++++	✗
ALADIN*	✗	2	240 8,5	+	+	++++	++	++	+++	✗	+	+
ALADIN PLUS*	✗	2	435 15,3	+	+	++++	✗	+++	+++	✗	+	+

++++ THE BEST +++ MORE SUITABLE ++ SUITABLE + LESS SUITABLE ✗ UNSUITABLE

* note: Do not use a chest harness alone! Must be worn with a sit harness.



SIT		CODE	SIZE	WEIGHT gloz	WAIST SIZE cm/in	LEG LOOPS cm/in	MATERIAL	STANDARD	€€
ROCKET		C5076BX01	XS	230 8.11	49 19.5	49 19	55% PAD, 16% EVA foam, 15% PE, 8% steel, 6% PES	EN 12277 •	€€1019
		C5076BX02	S	240 8.47	52 20.5	52 20			
		C5076BX03	M	250 8.82	55 21.5	55 21			
		C5076BX04	L	260 9.17	58 23	58 22			
ONYX		C5082ZH01	XS	305 10.76	52 20.5	49 19	47% PES, 27% PAD, 9% steel, 9% EVA foam, 9% PP	EN 12277 •	€€1019
		C5082ZH02	S	315 11.11	52 20.5	52 20			
		C5082ZH03	M	335 11.82	55 21.5	55 21			
		C5082ZH04	L	355 12.52	58 23	58 23			
PEARL		C5083LX01	XS	330 11.64	50-55 19.5-21.5	45-50 17.5-19.5	44% PES, 25% PAD, 17% steel, 8% EVA foam, 6% PP	EN 12277 •	€€1019
		C5083LX02	S	350 12.35	50-55 19.5-21.5	50-55 19.5-21.5			
		C5083LX03	M	365 12.87	55-60 21.5-23.5	55-60 21.5-23.5			
		C5083LX04	L	385 13.58	60-65 23.5-25.5	60-65 23.5-25.5			
GARNET		C5084MX01	XS	355 12.52	50-55 19.5-21.5	45-50 17.5-19.5	44% PES, 25% PAD, 17% steel, 8% EVA foam, 6% pp	EN 12277 •	€€1019
		C5084MX02	S	365 12.87	50-55 19.5-21.5	50-55 19.5-21.5			
		C5084MX03	M	380 13.40	55-60 21.5-23.5	55-60 21.5-23.5			
		C5073RT04	L	390 13.76	60-65 23.5-25.5	60-65 23.5-25.5			
		C5084MX05	XL	400 14.11	65-70 25.5-27.5	65-70 25.5-27.5			
		C5084MX06	XXL	410 14.46	65-70 25.5-27.5	65-70 25.5-27.5			
		C5084HX01	XS	350 12.35	50-55 19.5-21.5	45-50 17.5-19.5			
		C5084HX02	S	360 12.70	50-55 19.5-21.5	50-55 19.5-21.5			
		C5084HX03	M	370 13.05	55-60 21.5-23.5	55-60 21.5-23.5			
		C5084HX04	L	385 13.58	60-65 23.5-25.5	60-65 23.5-25.5			
		C5084HX05	XL	400 14.11	65-70 25.5-27.5	65-70 25.5-27.5			
		C5084HX06	XXL	410 14.46	65-70 25.5-27.5	65-70 25.5-27.5			
SPINEL		C5084MX05	S	390 13.76	50-55 19.5-21.5	50-55 19.5-21.5	44% PES, 22% PAD, 20% steel, 8% EVA foam, 6% pp	EN 12277 •	€€1019
		C5084MX05	M/L	415 14.64	55-63 23.5-24.8	60-65 23.5-25.5			
		C5084MX05	XL	435 15.34	65-70 25.5-27.5	65-70 25.5-27.5			
VERSA II		C5067BO03	XS-M	410 14.46	65-90 25.5-35.5	45-58 18-23	66% PAD, 16% steel, 11% EVA foam, 5% PES, 2% PVC	EN 12277 •	€€1019
		C5067BO05	L-XXL	435 14.99	75-100 29.5-39.5	55-68 21.5-26.5			
ROB		C5075OX01	XS	300 10.58	65-75 25.5-29.5	49 19	66% PAD, 12% steel, 11% EVA foam, 7% PES, 4% PVC	EN 12277 •	€€1019
		C5075OX02	S	320 11.29	70-80 27.5-31.5	52 20			
		C5075OX03	M	335 11.82	75-85 29.5-33.5	55 21			
		C5075OX04	L	345 12.17	80-90 31.5-35.5	58 23			
		C5075OX05	XL	355 12.52	85-95 33.5-37.5	60 23			
		C5075OX06	XXL	360 12.70	90-100 35.5-39.5	60 23			
RAY		C5038OS01	XS	350 12.35	65-75 25.5-29.5	45-50 17.5-19.5	66% PAD, 16% steel, 11% EVA foam, 5% PES, 2% PVC	EN 12277 •	€€1019
		C5038OS02	S	365 12.87	70-80 27.5-31.5	50-55 19.5-21.5			
		C5038OS03	M	385 13.58	75-85 29.5-33.5	55-60 21.5-23.5			
		C5038OS04	L	400 14.11	80-90 31.5-35.5	60-65 23.5-25.5			
		C5038OS05	XL	410 14.46	85-95 33.5-37.5	65-70 25.5-27.5			
		C5038OS06	XXL	415 14.64	90-100 35.5-39.5	65-70 25.5-27.5			
DOME		C5080SS01	S	585 20.64	65-80 25.5-31.5	50-59 19.7-23.2	50% PAD, 17% steel, 12% EVA foam, 8% PVC, 7% PES, 6% PP	EN 12277 •	€€1019
		C5080SS02	M/L	630 22.22	75-90 29.5-35.5	55-64 21.7-25.2			
		C5080SS05	XL	675 23.81	85-100 33.5-39.5	60-69 23.6-27.1			



CHILDREN'S		CODE	SIZE	WEIGHT gloz	WAIST SIZE cm in	LEG LOOPS cm in	HEIGHT cm in	MATERIAL	STANDARD	€€
ARA		Three-buckle children's climbing harness for small rock stars. With this harness, they'll be safe and comfortable at heights.	C5086LX01	K1	275 9.70	55-65 21.5-25.5	35-40 14-16	43 % PES, 22 % PAD, 21 % steel, 8 % EVA foam, 6 % PP	EN 12277 •	€€ 1019
			C5086LX02	K2	283 9.98	60-70 23.5-27.5	40-45 16-17.5			
ZAZA		C5069OA00	UNI	338 11.92	×	×	95-130 37-51	66 % PAD, 16 % steel, 11 % EVA foam, 5 % PES, 2 % PVC	EN 12277 •	€€ 1019

FULLBODY

TARZAN ECONOMIC		Fully adjustable full body fall arrest harness intended for rope courses and adventure parks.	W0059BR01	Small	960 33.86	×	×	110-150 43-59	60 % PAD, 28 % steel, 7 % light alloy, 5 % PE	EN 361 EN 12277	€€ 1019
			W0059BR00	UNI	1050 37.04	×	×				
COMPLETE		Full body harness suitable for via ferrata and for climbing beginners.	C0710BS	UNI	520 18.34	×	×	140-200 55-78	40 % PES, 40 % PAD, 11,5 % steel, 8 % PE, 0,5 % PVC,	EN 12277 •	€€ 1019
ROPEDANCER II		Fully adjustable full body harness with various attachment points intended for rope courses and adventure parks.	W0087BY01	XS	1150 40.57	×	×	125-155 49-61	55 % PES, 25 % PAD, 12 % steel, 6 % light alloy, 2 % PE	EN 12277 •	€€ 1019
			W0087BY03	S/M/L	1195 42.15	×	×	150-185 59-73			
			W0087BY05	XL/XXL	1275 44.97	×	×	180-210 70-83			

SKI TOURING & VIA FERRATA HARNESSES		CODE	SIZE	WEIGHT gloz	WAIST SIZE cm in	LEG LOOPS cm in	MATERIAL	STANDARD	€€	
TOP		Universal harness for all climbers from children to adults especially suitable for climbing schools, gyms, via ferrata or glacier tours.	C5031BS00	UNI	366 12.91	60-120 24-47	42-66 17-27	40 % PES, 40 % PA, 11,5 % steel, 8 % PE, 0,5% PVC	EN 12277 •	€€ 1019
			C5031BB00	UNI	366 12.91	60-120 24-47	42-66 17-27			
TOP PADDED		Harness with simple design and padded leg loops mainly for climbing schools, gyms, via ferrata or glacier tours.	C5032BS00	UNI	402 14.18	60-120 24-47	42-66 17-27	40 % PES, 40 % PA, 11,5 % steel, 8 % PE, 0,5% PVC	EN 12277 •	€€ 1019
TOP RENTAL		Padded sit harness with three buckles suitable mainly for beginners, rentals in climbing gyms or rope courses.	C5078RB01	XS - M	395 13.93	55-90 22-35	35-65 14-25	50 % PAD, 25 % PES, 14 % steel, 11 % EVA foam	EN 12277 •	€€ 1019
			C5078RB04	L - XXL	445 15.70	75-125 29-49	40-75 16-29			
			C5078SB01	XS - M	395 13.93	55-90 22-35	35-65 14-25			
			C5078SB04	L - XXL	445 15.70	75-125 29-49	40-75 16-29			
SERAC		Extremely lightweight harness for ski touring, mountaineering and glacier tours. Also widely used for climbing on via ferratas.	C5079WB02	S	92 3.25	71-83 28-32.6	48-55 19-21.6	42 % HMPE, 37 % PAD, 12 % light aluminium alloy, 4 PES, 3 % POM, 2 % rubber	EN 12277 •	€€ 1019
			C5079WB03	M	96 3.39	78-90 30.7-35.4	53-60 20.8-23.6			
			C5079WB04	L	99 3.49	85-97 33.4-38.2	58-65 22.8-25.6			
			C5079WB05	XL	102 3.60	92-104 36.2-40.9	63-70 24.8-27.5			
			C5079WB06	XXL	106 3.74	99-111 39-43.7	68-75 26.8-29.5			



CANYONING & SPELEO HARNESSES		CODE	SIZE	WEIGHT gloz	WAIST SIZE cm/in	LEG LOOPS cm/in	MATERIAL	STANDARD	CE
CANYON XP 	Fully adjustable canyoning harness for advanced users.	C5030BS02	S	610 21.52	70-100 28-40	42-66 17-27	56 % PAD, 17 % PES, 12 % Steel, 7 % EVA foam, 4 % Rubber, 4 % PVC	EN 12277 •	CE1019
		C5030BS03	M/L	620 21.87	80-110 32-43	42-66 17-27			
		C5030BS05	XL	630 22.22	90-120 36-48	42-66 17-27			
CANYON SIT PROTECTION 	Replacement sit reinforcement for canyoning harnesses from welded abrasion resistant fabric.	C9630BB00	UNI	150 5.29	×	×	PVC	×	×
TOP CANYON 	Fully adjustable canyoning harness for canyoning schools and centers.	C5029BS00	UNI	502 17.71	60-120 24-47	42-66 17-27	62 % PAD, 19 % PES, 14 % Steel, 5 % PVC	EN 12277 •	CE1019
DIGGER LIGHT 	Speleo harness with fully adjustable waist belt and leg loops.	S0101YB00	UNI	550 19.40	60-120 24-47	50-80 20-31	57 % PAD, 20 % steel, 18 % light alloys, 3 % PVC	EN 12277 •	CE1019

CHEST HARNESSES		CODE	SIZE	WEIGHT gloz	CHEST WIDTH cm/in	MATERIAL	STANDARD	CE
ALADIN 	Simple chest harness designed to be used together with a sit harness.	C5056BY00	UNI	240 8.47	75-110 30-43	40 % PES, 40 % PAD, 11,5 % steel, 8 % PE, 0,5 % PVC	EN 12277 •	CE1019
		C5056BB00	UNI					
ALADIN PLUS 	Padded comfortable chest harness designed to be used together with a sit harness.	C5057BY00	UNI	435 15.34	75-110 30-43	70 % PAD, 20 % steel, 6 % EVA foam, 2 % PES, 2 % PVC	EN 12277 •	CE1019
ALADIN PADDING 	Padding for the chest harness ALADIN.	C5058	UNI	195 6.88	75-110 30-43	60 % EVA foam, 32 % PAD, 5 % PVC, 3 % steel	×	×

CLIMBING HARNESSES – PACKETS		CODE	SIZE	WEIGHT gloz	WAIST SIZE cm/in	LEG LOOPS cm/in	STANDARD	CE
PACKET RAY 	Perfect choice for beginners who prefer single pitch or gym climbing. Set includes Ray harness, Oxy screw carabiner and Rama belay device.	M0029XX01	XS	508 17.92	65-75 25.5-29.5	45-50 17.5-19.5	EN 12277 EN 362 EN12275 EN15151-2 	CE1019
		M0029XX02	S	523 18.45	70-80 27.5-31.5	50-55 19.5-21.5		
		M0029XX03	M	543 19.15	75-85 29.5-33.5	55-60 21.5-23.5		
		M0029XX04	L	558 19.68	80-90 31.5-35.5	60-65 23.5-25.5		
		M0029XX05	XL	568 20.04	85-95 33.5-37.5	65-70 25.5-27.5		
		M0029XX06	XXL	573 20.21	90-100 35.5-39.5	65-70 25.5-27.5		
LADY PACKET 	Unique set for all women who climbs in the gym or out at the crags. Set includes Pearl harness, Buddy set, chalk bag including a chalk bag belt.	M0014XX01	XS	538 18.98	60-70 23.5-27.5	45-50 17.5-19.5	EN 12277 EN 362 EN12275 EN15151-2 	CE1019
		M0014XX02	S	558 19.68	65-75 25.5-29.5	50-55 19.5-21.5		
		M0014XX03	M	573 20.21	70-80 27.5-31.5	55-60 21.5-23.5		
		M0014XX04	L	593 20.92	75-85 29.5-33.5	60-65 23.5-25.5		
		M0014XX05	XL	623 21.98	80-90 31.5-35.5	65-70 25.5-27.5		
GYM PACKET 	Perfect choice for all who climb indoor or prefer single pitch climbing. Packet includes Versa II harness, Oxy screw carabiner, Rama belay device, chalk bag Large including a chalk bag belt and Magnum ball.	M0027XX03	XS-M	695 24.52	65-90 25.5-35.5	45-58 18-23	EN 12277 EN 362 EN12275 EN15151-2 	CE1019
		M0027XX05	L-XXL	710 25.04	75-100 29.5-39.5	55-68 21.5-26.5		







THERMO-TRANSFER

Thermotransfer end marking of Singing Rock ropes.
Special etiquette applied to the rope sheath by the heat and pressure. This marking ID is durable and does not create any broad forms on the ends of the ropes which can stuck e.g. when pulling down the rope from rappel station.

ULTRASONIC

an excellent way of rope ending

Our own special technology has been used for the ends of the rope.

All SINGING ROCK ropes are ended by a unique technology ULTRASONIC. It means that the loadbearing core and the protective sheath are joined into a compact unit in the last 15 mm of the rope.



UIAA WATER REPELENT

A standard for water repellent ropes approved by the UIAA Safety Commission. To pass the test at a certified laboratory, the amount of absorbed water must not be greater than 5% of the rope's weight. For comparison, a non-treated rope absorbs around 50 % of water in this test, and ropes labelled as "dry" but lacking adequate treatments can absorb between 20 % and 40 % of water.



STITCHED EYE

an excellent way of rope ending

Selected SINGING ROCK static ropes which are marked with Stitched eye icon are possible to produce with one or two stitched eyes at the end of the rope.



INTERCORE

The unique patented technology providing maximum safety even in case of a damaged sheath. The rope is made from 4 layers of parallel core filaments, braided core, braided intermediate sheath made from staple fibres and single tech sheath.



MIDDLE MARKING

At half of the length, the rope is visibly marked by colour, which does not affect the core structure and its mechanical properties.



ROUTE 44

experience the touch of the future

Route 44 is unique technology invented and patented by Singing Rock. It opens new horizons for braiding of climbing and static ropes.

Route 44 technology allows blending of properties that were considered impossible before. Rope braided by using Route 44 technology is more compact, softer and above all it is more durable than conventional rope.

All that is achieved by making no compromises in using correct sheath thickness, which is round-braided by 44 carriers. These features combine to give you better rope.



SINGLE TECH

With the single tech system each strand is braided into the sheath separately. Single tech sheath construction increases the rope's wear resistance and improves the rope's mechanical properties, such as flexibility.

Types of static ropes:

Type A rope – low stretch kernmantel rope designed for general use by persons in rope access including all kinds of work positioning and restraint; in rescue and in caving.

Type B rope – low stretch kernmantel rope of a lower performance than type A ropes, requiring greater care in use (standard does not content other specification).

Static strength defined in the standard:

22 kN for the ropes of type A
18 kN for the ropes of type B
Another standard requirement says, the material used for rope production shall have the melting point higher than 195 °C, so polyethylene or polypropylene are not suitable for the production of the ropes.

Rope elongation

The rope elongation shall not be higher than 5 %, tested by loading the rope for 3 min with 150 kg load (pretension 50 kg)

Dynamic performance

Fall test with two meters long rope terminated with figure-eight knots; fall factor 1.
The testing mass 100 kg for type A ropes, 80 kg for type B ropes.

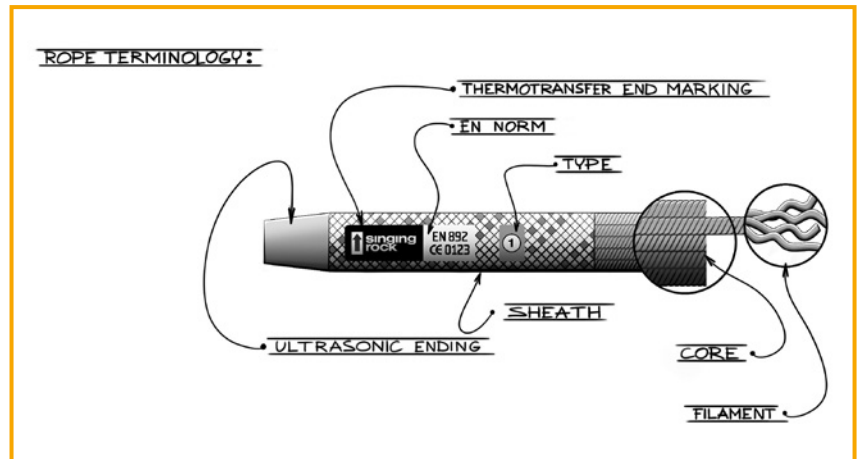







TECHNOLOGIES OF SINGING ROCK ROPES

PRODUCT NAME	TECHNOLOGY					
	ROUTE 44	INTERCORE	SINGLE TECH	ULTRASONIC	MIDDLE MARKING	WATER REPELLENT
GEMINI DRY 7.9	x	x	x	✓	x	✓
ACCORD DRY 8.3	x	x	x	✓	x	✓
ACCORD 8.3	x	x	x	✓	x	x
DNA DRY 8.9	x	x	x	✓	✓	✓
ICON DRY 9.3	✓	x	x	✓	✓	✓
ICON 9.3	✓	x	x	✓	✓	x
HERO DRY 9.6	x	x	✓	✓	✓	✓
HERO 9.6	x	x	✓	✓	✓	x
KATA DRY 9.7	x	✓	✓	✓	✓	✓
KATA 9.7	x	✓	✓	✓	✓	x
STORM DRY 9.8	x	x	x	✓	✓	✓
STORM 9.8	x	x	x	✓	✓	x
GYM 10.1	x	x	x	✓	x	x
SCORE DRY 10.1	✓	x	x	✓	✓	✓
SCORE 10.1	✓	x	x	✓	✓	x
DURAN 10.4	✓	x	x	✓	✓	x
PATRON 11.0	x	x	x	✓	✓	x
<hr/>						
STATIC R44 11.0	✓	x	x	✓	x	x
STATIC R44 10.5	✓	x	x	✓	x	x
STATIC 11	x	x	x	✓	x	x
STATIC 10.5	x	x	x	✓	x	x
CONTRA 10.5	x	x	x	✓	x	x
STATIC 9.0	x	x	x	✓	x	x



















TECHNOLOGIES OF SINGING ROCK ROPES

PRODUCT NAME	TECHNOLOGY					
	ROUTE 44	INTERCORE	SINGLE TECH	ULTRASONIC	MIDDLE MARKING	WATER REPELENT
STATIC R44 NFPA 13 	✓	×	×	✓	×	×
STATIC R44 NFPA 11 	✓	×	×	✓	×	×
STATIC R44 NFPA 10.5 	✓	×	×	✓	×	×
SPELEO R44 10.5 	✓	×	×	✓	×	×
SPELEO 10.5 	×	×	×	✓	×	×

Choose your dynamic rope of various diameters for sport climbing, gym climbing, mountaineering and other vertical activities.

RECOMMENDED USE OF SINGING ROCK ROPES

PRODUCT NAME	ACTIVITY									
	SPORT CLIMBING	GYM CLIMBING	TRAD CLIMBING, BIG WALL	GLACIER TRAVEL, CLASSIC MOUNTAINEERING	TECHNICAL MOUNTAINEERING, ICE CLIMBING	SKITOURING, EXPEDITIONS	CAVING	HAULING	ROPE ACCESS	RESCUE
GEMINI DRY 7.9 	+	+	++++	++++	++++	+++	×	×	×	×
ACCORD DRY 8.3 	+	+	++++	++++	++++	+++	×	×	×	×
ACCORD 8.3 	+	+	++++	+++	+	+	×	×	×	×
DNA DRY 8.9 	++++	+++	+++	++++	+++	+++	×	×	×	×
ICON DRY 9.3 	++++	+++	++	+++	+	+	×	×	×	×
ICON 9.3 	++++	+++	++	+	+	+	×	×	×	×
HERO DRY 9.6 	++++	+++	++	++	++	++	×	×	×	×
HERO 9.6 	++++	+++	++	+	+	+	×	×	×	×
KATA DRY 9.7 	++++	+++	++	++	++	++	×	×	×	×
KATA 9.7 	++++	+++	++	+	+	+	×	×	×	×
STORM DRY 9.8 	++++	+++	++	++	++	++	×	×	×	×
STORM 9.8 	+++	+++	++	+	+	+	×	×	×	×
GYM 10.1 	++	++++	++	+	+	+	×	×	×	×
SCORE DRY 10.1 	+++	++++	++	+	+	+	×	×	×	×
SCORE 10.1 	++	++++	++	+	+	+	×	×	×	×
DURAN 10.4 	+	++++	++	+	+	+	×	×	×	×
PATRON 11.0 	+	+++	++	+	+	+	×	×	×	++++







RECOMMENDED USE OF SINGING ROCK ROPES

PRODUCT NAME	ACTIVITY									
	SPORT CLIMBING	GYM CLIMBING	TRAD CLIMBING. BIG WALL	GLACIER TRAVEL. CLASSIC MOUNTAINEERING	TECHNICAL MOUNTAINEERING. ICE CLIMBING	SKITOURING. EXPEDITIONS	CAVING	HAULING	ROPE ACCESS	RESCUE
STATIC R44 11.0	x	x	x	x	x	x	+	++	++++	+++
STATIC R44 10.5	x	x	x	x	x	x	+	++	++++	++
STATIC 11	x	x	x	x	x	x	+	++	++++	+++
STATIC 10.5	x	x	x	x	x	x	+	++	++++	++
CONTRA 10.5	x	x	x	x	x	x	+	+++	++++	++
STATIC 9.0	x	x	++	x	x	++	+	++++	++	+
STATIC R44 NFPA 13	x	x	x	x	x	x	+	++	+++	++++
STATIC R44 NFPA 11	x	x	x	x	x	x	+	++	++++	+++
STATIC R44 NFPA 10.5	x	x	++	x	x	x	+	++	++++	++
SPELEO R44 10.5	x	x	x	x	x	x	++++	+++	++	+
SPELEO 10.5	x	x	x	x	x	x	++++	+++	++	+

++++ THE BEST +++ MORE SUITABLE ++ SUITABLE + LESS SUITABLE x UNSUITABLE

Note: STATIC 9.0 for hauling only for trad climbing, big wall, expeditions









DYNAMIC ROPES		CODE	COLOR	LENGTH m	DIAMETER mm	WEIGHT g/m	STATIC ELON- GATION %	DYNAMIC ELON- GATION %	NUMBER OF FALLS	IMPACT FORCE kN	TYPE	STANDARD	€€
GEMINI DRY 7.9 	Half & twin rope for mountaineering, ice climbing or glacier tours with special water repellent treatment.	L3020YX03	yellow	30 m	7.9	39	8 (twin); 10.5 (half)	33 (twin); 38 (half)	16 (twin); 5 (half)	7.9 (twin); 5.1 (half)	half-twin	EN 892 A Ω	€€ 1019
		L3020YX04		40 m									
		L3020YX05		50 m									
		L3020YX06		60 m									
		L3020YX07		70 m									
		L3020YX08		80 m									
		L3020YX10		100 m									
		L3021YX20	200 m spool										
		L3020RX03	red	30 m									
		L3020RX04		40 m									
		L3020RX05		50 m									
		L3020RX06		60 m									
		L3020RX07		70 m									
		L3020RX08		80 m									
		L3020RX10		100 m									
		L3021RX20	200 m spool										
ACCORD DRY 8.3 	Half and twin rope with excellent durability and special water repellent treatment.	L0514OG03	orange	30 m	8.3	43	6.4 (twin); 11 (half)	34 (twin); 33 (half)	15 (twin); 5 (half)	9.7 (twin); 6.3 (half)	half-twin	EN 892 A Ω	€€ 1019
		L0514OG04		40 m									
		L0514OG05		50 m									
		L0514OG06		60 m									
		L0514OG07		70 m									
		L0514OG08		80 m									
		L0514OG10		100 m									
		L0515GO20	200 m spool										
		L0514GO03	green	30 m									
		L0514GO04		40 m									
		L0514GO05		50 m									
		L0514GO06		60 m									
		L0514GO07		70 m									
		L0514GO08		80 m									
		L0514GO10		100 m									
		L0515GO20	200 m spool										
ACCORD 8.3 	Durable half & twin rope for trad climbing.	L0510GA03	green	30 m	8.3	43	6.4 (twin); 11 (half)	34 (twin); 33 (half)	15 (twin); 5 (half)	9.7 (twin); 6.3 (half)	half-twin	EN 892 A Ω	€€ 1019
		L0510GA04		40 m									
		L0510GA05		50 m									
		L0510GA06		60 m									
		L0510GA07		70 m									
		L0510GA08		80 m									
		L0510GA10		100 m									
		L0511GA20	200 m spool										
		L0510AG03	blue	30 m									
		L0510AG04		40 m									
		L0510AG05		50 m									
		L0510AG06		60 m									
		L0510AG07		70 m									
		L0510AG08		80 m									
		L0510AG10		100 m									
		L0511AG20	200 m spool										
DNA DRY 8.9 	One rope for all your climbing activities. Suitable for sport climbing and also for mountaineering and glacier tours thanks to its lightness and water resistance.	L3060CX03	pink	30m	8.9	51	5 (single); 5 (half); 4 (twin)	30 (single); 27 (half); 25 (twin)	6 (single); 15 (half); 30 (twin)	9.9	single, twin and half	EN 892 A Ω	€€ 1019
		L3060CX04		40m									
		L3060CX05		50m									
		L3060CX06		60m									
		L3060CX07		70m									
		L3060CX08		80m									
		L3060CX10		100m									
		L3061CX20		200 m spool									











DYNAMIC ROPES		CODE	COLOR	LENGTH m	DIAMETER mm	WEIGHT g/m	STATIC ELON- GATION %	DYNAMIC ELON- GATION %	NUMBER OF FALLS	IMPACT FORCE kJ	TYPE	STANDARD	CE
<p>ICON DRY 9.3</p>	Lightweight and water resistant single rope made with patented R44 technology for your sport climbing projects.	L0384RX03	red	30 m	9.3	56	7.5	34	5	8.6	single	EN 892	CE 1019
		L0384RX04		40 m									
		L0384RX05		50 m									
		L0384RX06		60 m									
		L0384RX07		70 m									
		L0384RX08		80 m									
		L0384RX10		100 m									
		L0385RX20		200 m spool									
<p>ICON 9.3</p>	Lightweight single rope made with patented R44 technology for your sport climbing projects.	L0380YX03	yellow	30 m	9.3	56	7.5	34	5	8.6	single	EN 892	CE 1019
		L0380YX04		40 m									
		L0380YX05		50 m									
		L0380YX06		60 m									
		L0380YX07		70 m									
		L0380YX08		80 m									
		L0380YX10		100 m									
		L0381YX20		200 m spool									
<p>HERO DRY 9.6</p>	Top-class water resistant single rope with low weight for high-level climbers.	L0524GW03	blue	30 m	9.6	59	5.1	35	8	7.9	single	EN 892	CE 1019
		L0524GW04		40 m									
		L0524GW05		50 m									
		L0524GW06		60 m									
		L0524GW07		70 m									
		L0524GW08		80 m									
		L0524GW10		100 m									
		L0525GW20		200 m spool									
<p>HERO 9.6</p>	Single rope with great handling for sport climbers.	L0520GA03	green	30 m	9.6	59	5.1	35	8	7.9	single	EN 892	CE 1019
		L0520GA04		40 m									
		L0520GA05		50 m									
		L0520GA06		60 m									
		L0520GA07		70 m									
		L0520GA08		80 m									
		L0520GA10		100 m									
		L0521GA20		200 m spool									
<p>KATA DRY 9.7</p>	High-end water resistant single rope with high safety factors and extremely high durability. Suitable for both experienced climbers and beginners.	L0580AA03	blue	30 m	9.7	61	9	30	5	7.7	single	EN 892	CE 1019
		L0580AA04		40 m									
		L0580AA05		50 m									
		L0580AA06		60 m									
		L0580AA07		70 m									
		L0580AA08		80 m									
		L0580AA10		100 m									
		L0581AA20		200 m spool									
<p>KATA 9.7</p>	High-end climbing single rope with high safety factors and extremely high durability. Suitable for both experienced climbers and beginners.	L0570AA03	light blue	30 m	9.7	61	9	30	5	7.7	single	EN 892	CE 1019
		L0570AA04		40 m									
		L0570AA05		50 m									
		L0570AA06		60 m									
		L0570AA07		70 m									
		L0570AA08		80 m									
		L0570AA10		100 m									
		L0571AA20		200 m spool									
<p>STORM DRY 9.8</p>	Water resistant single rope with great balance in weight, durability and use. Perfect choice for all-round climbing.	L3044AG03	blue	30m	9.8	65	7.9	35	9	9.1	single	EN 892	CE 1019
		L3044AG04		40m									
		L3044AG05		50m									
		L3044AG06		60m									
		L3044AG07		70m									
		L3044AG08		80m									
		L3044AG10		100m									
		L3045AG20		200 m spool									









DYNAMIC ROPES		CODE	COLOR	LENGTH m	DIAMETER mm	WEIGHT g/m	STATIC ELON- GATION %	DYNAMIC ELON- GATION %	NUMBER OF FALLS	IMPACT FORCE kN	TYPE	STANDARD	€€
STORM 9.8 	Single rope with great balance in weight, durability and use. Perfect choice for all-round climbing.	L3040GA03	green	30 m	9.8	65	7.9	35	9	9.1	single	EN 892 ⚠	€€ 1019
		L3040GA04		40 m									
		L3040GA05		50 m									
		L3040GA06		60 m									
		L3040GA07		70 m									
		L3040GA08		80 m									
		L3040GA10		100 m									
		L3041GA20		200 m spool									
GYM 10.1 	Single rope specially invented for climbing gyms, adventure parks or rope courses.	L3050RY03	red	30 m	10.1	67.8	7.4	37	7	7.9	single	EN 892 ⚠	€€ 1019
		L3050RY04		40 m									
		L3050RY05		50 m									
		L3050RY06		60 m									
		L3050RY07		70 m									
		L3050RY08		80 m									
		L3050RY10		100 m									
		L3051RY20		200 m spool									
SCORE DRY 10.1 	Water resistant single rope for the gym or crags.	L0364LA03	mint	30 m	10.1	66	7	32	8	9.5	single	EN 892 ⚠	€€ 1019
		L0364LA04		40 m									
		L0364LA05		50 m									
		L0364LA06		60 m									
		L0364LA07		70 m									
		L0364LA08		80 m									
		L0364LA10		100 m									
		L0365LA20		200 m spool									
SCORE 10.1 	Great single rope for the gym or crags with shiny colour.	L0360GG03	green	30 m	10.1	66	7	32	8	9.5	single	EN 892 ⚠	€€ 1019
		L0360GG04		40 m									
		L0360GG05		50 m									
		L0360GG06		60 m									
		L0360GG07		70 m									
		L0360GG08		80 m									
		L0360GG10		100 m									
		L0361GG20		200 m spool									
DURAN 10.4 	Durable rope for rope courses and gym climbing.	L0340AX03	blue	30 m	10.4	70	7.1	31	9	9.1	single	EN 892 ⚠	€€ 1019
		L0340AX04		40 m									
		L0340AX05		50 m									
		L0340AX06		60 m									
		L0340AX07		70 m									
		L0340AX08		80 m									
		L0340AX10		100 m									
		L0341AX20		200 m spool									
PATRON 11.0  	Dynamic single rope with high safety factor and great durability.	L0540BB03	black	30 m	11	79	5.3	31	16	9.1	single	EN 892 ⚠	€€ 1019
		L0540BB04		40 m									
		L0540BB05		50 m									
		L0540BB06		60 m									
		L0540BB07		70 m									
		L0540BB08		80 m									
		L0540BB10		100 m									
		L0541BB20		200 m spool									
		L0540YX03	30 m										
		L0540YX04	40 m										
		L0540YX05	50 m										
		L0540YX06	60 m										
		L0540YX07	70 m										
		L0540YX08	80 m										
		L0540YX10	100 m										
		L0541YX20	200 m spool										









LOW STRETCH ROPES		CODE	COLOR	LENGTH	DIAMETER mm	WEIGHT g/m	STATIC ELON- GATION %	STRENGTH kN	KNOT BREAKING FORCE kN	NUMBER OF FALLS	TYPE	STANDARD	CE
STATIC R44 11.0    	Excellent quality STA- TIC rope intended for rope access, work positioning, rescue or manipulation with the objects.	L0450BB03	black	30 m	11	77	3.2	34.9	22.3	20	A	EN 1891 	CE1019
		L0450BB04		40 m									
		L0450BB05		50 m									
		L0450BB06		60 m									
		L0450BB07		70 m									
		L0450BB08		80 m									
		L0450BB10		100 m									
		L0451BB10		100 m spool									
		L0451BB20		200 m spool									
		L0450OO03		orange									
		L0450OO04	40 m										
		L0450OO05	50 m										
		L0450OO06	60 m										
		L0450OO07	70 m										
		L0450OO08	80 m										
		L0450OO10	100 m										
		L0451OO10	100 m spool										
		L0451OO20	200 m spool										
		L0450RR03	red										
		L0450RR04		40 m									
		L0450RR05		50 m									
		L0450RR06		60 m									
		L0450RR07		70 m									
		L0450RR08		80 m									
		L0450RR10		100 m									
		L0451RR10		100 m spool									
		L0451RR20		200 m spool									
		L0450WG03		white									
		L0450WG04	40 m										
		L0450WG05	50 m										
		L0450WG06	60 m										
		L0450WG07	70 m										
L0450WG08	80 m												
L0450WG10	100 m												
L0451WG10	100 m spool												
L0451WG20	200 m spool												
STATIC R44 10.5  	Low stretch rope type A designed for gen- eral use with patented rope-braiding technol- ogy ROUTE 44.	L0430BB03	black		30 m	10.5	72	3.4	31.5	19.8	15	A	EN 1891 
		L0430BB04		40 m									
		L0430BB05		50 m									
		L0430BB06		60 m									
		L0430BB07		70 m									
		L0430BB08		80 m									
		L0430BB10		100 m									
		L0431BB10		100 m spool									
		L0431BB20		200 m spool									
		L0430KK03		khaki	30 m								
		L0430KK04	40 m										
		L0430KK05	50 m										
		L0430KK06	60 m										
		L0430KK07	70 m										
		L0430KK08	80 m										
		L0430KK10	100 m										
		L0431KK10	100 m spool										
		L0431KK20	200 m spool										











LOW STRETCH ROPES		CODE	COLOR	LENGTH	DIAMETER mm	WEIGHT g/m	STATIC ELON- GATION %	STRENGTH kN	KNOT BREAKING FORCE kN	NUMBER OF FALLS	TYPE	STANDARD	CE											
STATIC R44 10.5  	Low stretch rope type A designed for general use with patented rope-braiding technology ROUTE 44.	L0430RR03	red	30 m	10.5	72	3.4	31.5	19.8	15	A	EN 1891 	CE 1019											
		L0430RR04		40 m																				
		L0430RR05		50 m																				
		L0430RR06		60 m																				
		L0430RR07		70 m																				
		L0430RR08		80 m																				
		L0430RR10		100 m																				
		L043IRR10		100 m spool																				
		L043IRR20		200 m spool																				
		L0430WR03		30 m																				
		L0430WR04	40 m																					
		L0430WR05	50 m																					
		L0430WR06	60 m																					
		L0430WR07	70 m																					
		L0430WR08	80 m																					
		L0430WR10	100 m																					
		L0431WR10	100 m spool																					
		L0431WR20	200 m spool																					
		STATIC 11.0   	STATIC rope for workers at height, rescuers, firemen, cavers and other professionals when working every day.	L0250BB03										black	30 m	11	80	3.3	34.5	22	20	A	EN 1891 	CE 1019
				L0250BB04											40 m									
L0250BB05	50 m																							
L0250BB06	60 m																							
L0250BB07	70 m																							
L0250BB08	80 m																							
L0250BB10	100 m																							
L025IBB10	100 m spool																							
L025IBB20	200 m spool																							
L0250RR03	30 m																							
L0250RR04	40 m																							
L0250RR05	50 m																							
L0250RR06	60 m																							
L0250RR07	70 m																							
L0250RR08	80 m																							
L0250RR10	100 m																							
L025IRR10	100 m spool																							
L025IRR20	200 m spool																							
L0250WR03	30 m																							
L0250WR04	40 m																							
L0250WR05	50 m																							
L0250WR06	60 m																							
L0250WR07	70 m																							
L0250WR08	80 m																							
L0250WR10	100 m																							
L0251WR10	100 m spool																							
L0251WR20	200 m spool																							







LOW STRETCH ROPES		CODE	COLOR	LENGTH	DIAMETER mm	WEIGHT g/m	STATIC ELON- GATION %	STRENGTH kN	KNOT BREAKING FORCE kN	NUMBER OF FALLS	TYPE	STANDARD	CE
STATIC 10.5    	<p>Low stretch rope type A intended for rope access, work positioning, rescue, caving or manipulation with the objects.</p>	L0230BB03	black	30 m	10.5	69	3.3	30.4	18.6	10	A	EN 1891 	CE 1019
		L0230BB04		40 m									
		L0230BB05		50 m									
		L0230BB06		60 m									
		L0230BB07		70 m									
		L0230BB08		80 m									
		L0230BB10		100 m									
		L0231BB10		100 m spool									
		L0231BB20		200 m spool									
		L0230KK03		khaki									
		L0230KK04	40 m										
		L0230KK05	50 m										
		L0230KK06	60 m										
		L0230KK07	70 m										
		L0230KK08	80 m										
		L0230KK10	100 m										
		L0231KK10	100 m spool										
		L0231KK20	200 m spool										
		L0230RR03	red										
		L0230RR04		40 m									
		L0230RR05		50 m									
		L0230RR06		60 m									
		L0230RR07		70 m									
		L0230RR08		80 m									
		L0230RR10		100 m									
		L0231RR10		100 m spool									
		L0231RR20		200 m spool									
		L0230WR03		white									
L0230WR04	40 m												
L0230WR05	50 m												
L0230WR06	60 m												
L0230WR07	70 m												
L0230WR08	80 m												
L0230WR10	100 m												
L0231WR10	100 m spool												
L0231WR20	200 m spool												
CONTRA 10.5 	<p>All-purpose STATIC rope providing a balance between flexibility and abrasion resistance.</p>	L0260WX03	white		30 m	10.5	69	2	30.4	18.6	20	A	EN 1891 
		L0260WX04		40 m									
		L0260WX05		50 m									
		L0260WX06		60 m									
		L0260WX07		70 m									
		L0260WX08		80 m									
		L0260WX10		100 m									
		L0261WX10		100 m spool									
		L0261WX20		200 m spool									





LOW STRETCH ROPES		CODE	COLOR	LENGTH	DIAMETER mm	WEIGHT g/m	STATIC ELONGATION %	STRENGTH kN	KNOT BREAKING FORCE kN	NUMBER OF FALLS	TYPE	STANDARD	€€
STATIC 9.0  	STATIC rope type B. Low stretch rope of a lower performance than type A ropes, requiring greater care in use.	L0220BB03	black	30 m	9	54	3.3	24.4	13.6	15	B	EN 1891 	€€ 1019
		L0220BB04		40 m									
		L0220BB05		50 m									
		L0220BB06		60 m									
		L0220BB07		70 m									
		L0220BB08		80 m									
		L0220BB10		100 m									
		L0221BB10		100 m spool									
		L0221BB20		200 m spool									
		L0220WR03		white									
		L0220WR04	40 m										
		L0220WR05	50 m										
		L0220WR06	60 m										
		L0220WR07	70 m										
		L0220WR08	80 m										
		L0220WR10	100 m										
		L0221WR10	100 m spool										
		L0221WR20	200 m spool										

LOW STRETCH ROPES NFPA		CODE	COLOR	LENGTH	DIAMETER mm	WEIGHT g/m	STATIC ELONGATION %	STRENGTH kN	KNOT BREAKING FORCE kN	NUMBER OF FALLS	TYPE	STANDARD	€€
STATIC R44 NFPA 13 	Durable STATIC rope designed for general use for rope access and rescue. The rope meets the most demanding requirements of the North American NFPA standard, which demands the highest quality in everyday use.	R0460WB04	white	46 m/150 ft	13	108.7	3.4 % (at 1.35 kN, 300 lbs)	47	30		A	NFPA 1983 "G"	x
		R0460WB06		61 m/200 ft									
		R0460WB09		92 m/300 ft									
		R0461WB10		100 m/330 ft - spool									
		R0461WB18		183 m/600 ft - spool									
		R0461WB20		200 m/660 ft - spool									
STATIC R44 NFPA 11    	Durable STATIC rope designed for technical use for rope access and rescue. The rope meets the most demanding requirements of the North American NFPA standard, which demands the highest quality in everyday use.	R0450BB04	black	46 m/150 ft	11	77	3.0 % (at 1.35 kN, 300 lbs); 6.8 % (at 2.7 kN, 600 lbs); 10.8 % (at 4.4 kN, 1000 lbs)	33.5	x	x	A	NFPA 1983 „T“ EN 1891 	€€ 1019
		R0450BB06		61 m/200 ft									
		R0450BB09		92 m/300 ft									
		R0451BB010		100 m/330 ft - spool									
		R0451BB018		183 m/600 ft - spool									
		R0451BB020		200 m/660 ft - spool									
		R0450OO04	orange	46 m/150 ft									
		R0450OO06		61 m/200 ft									
		R0450OO09		92 m/300 ft									
		R0451OO010		100 m/330 ft - spool									
		R0451OO018		183 m/600 ft - spool									
		R0451OO020		200 m/660 ft - spool									
		R0450RR04	red	46 m/150 ft									
		R0450RR06		61 m/200 ft									
		R0450RR09		92 m/300 ft									
		R0451RR10		100 m/330 ft - spool									
		R0451RR18		183 m/600 ft - spool									
		R0451RR20		200 m/660 ft - spool									
		R0450WG04	white	46 m/150 ft									
		R0450WG06		61 m/200 ft									
R0450WG09	92 m/300 ft												
R0451WG10	100 m/330 ft - spool												
R0451WG18	183 m/600 ft - spool												
R0451WG20	200 m/660 ft - spool												













LOW STRETCH ROPES NFPA		CODE	COLOR	LENGTH	DIAMETER mm	WEIGHT g/m	STATIC ELON- GATION %	STRENGTH kN	KNOT BREAKING FORCE kN	NUMBER OF FALLS	TYPE	STANDARD	CE
STATIC R44 NFPA 10.5    	<p>Durable STATIC rope designed for technical use for rope access and rescue. The rope meets the most demanding requirements of the North American NFPA standard, which demands the highest quality in everyday use.</p>	R0430BB04	black	46 m/150 ft	10.5	72	3.5 % (at 1.35 kN, 300 lbs), 7.2 % (at 2.7 kN, 600 lbs), 9.9 % (at 4.4 kN, 1000 lbs)	32	X	X	A	NFPA 1983 „T” EN 1891	CE1019
		R0430BB06		61 m/200 ft									
		R0430BB09		92 m/300 ft									
		R0431BB10		100 m/330 ft - spool									
		R0431BB18		183 m/600 ft - spool									
		R0431BB20		200 m/660 fr - spool									
		R0430KK04	khaki	46 m/150 ft									
		R0430KK06		61 m/200 ft									
		R0430KK09		92 m/300 ft									
		R0431KK10		100 m/330 ft - spool									
		R0431KK18		183 m/600 ft - spool									
		R0431KK20		200 m/660 fr - spool									
		R0430RR04	red	46 m/150 ft									
		R0430RR06		61 m/200 ft									
		R0430RR09		92 m/300 ft									
		R0431RR10		100 m/330 ft - spool									
		R0431RR18		183 m/600 ft - spool									
		R0431RR20		200 m/660 fr - spool									
		R0430WR04	white	46 m/150 ft									
		R0430WR06		61 m/200 ft									
R0430WR09	92 m/300 ft												
R0431WR10	100 m/330 ft - spool												
R0431WR18	183 m/600 ft - spool												
R0431WR20	200 m/660 fr - spool												

SPELEO ROPES

SPELEO R44 10.5 	<p>STATIC rope with patented rope-braiding technology ROUTE 44 developed especially for cave exploring.</p>	L0440WR03	white	30 m	10.5	72	3.3	33.4	20	15	A	EN 1891	CE1019
		L0440WR04		40 m									
		L0440WR05		50 m									
		L0440WR06		60 m									
		L0440WR07		70 m									
		L0440WR08		80 m									
		L0440WR10		100 m									
		L0441WR10		100 m - spool									
		L0441WR20		200 m - spool									
		SPELEO 10.5 		<p>Speleological rope designed for smooth rappelling of long lengths. The rope behaves the same in wet and dirty conditions.</p>									
L0240WR04	40 m												
L0240WR05	50 m												
L0240WR06	60 m												
L0240WR07	70 m												
L0240WR08	80 m												
L0240WR10	100 m												
L0241WR10	100 m - spool												
L0241WR20	200 m - spool												



ACCESSORY CORDS		CODE	COLOR	LENGTH	DIAMETER mm	WEIGHT g/m	STRENGTH kN	STANDARD	€€
HAMMER CORD 2 mm 	Accessory cord for securing climbing or working gear	L002IXX00	grey	metrage	2	2.8	1.2	✗	✗
		L003IXX00	yellow	metrage	3	6.5	1.9	✗	✗
Accessory cords 4 mm 	Accessory cords for all vertical adventures. Rescue and self-protection.	L004IAGI0	blue	100 m spool	4	12.6	3.2	EN 564 ⚠	€€ 1019
Accessory cords 5 mm 	Accessory cords for all vertical adventures. Rescue and self-protection.	L005IOGI0	orange	100 m spool	5	18.7	5	EN 564 ⚠	€€ 1019
		L005IBBI0	black	100 m spool					
Accessory cords 6 mm 	Accessory cords for all vertical adventures. Rescue and self-protection.	L006IBBI0	black	100 m spool	6	23.2	9	EN 564 ⚠	€€ 1019
		L006IYGI0	yellow	100 m spool					
Accessory cords 7 mm 	Accessory cords for all vertical adventures. Rescue and self-protection.	L007IRGI0	red	100 m spool	7	35.1	11.5	EN 564 ⚠	€€ 1019
Accessory cords 8 mm 	Accessory cords for all vertical adventures. Rescue and self-protection.	L008IPGI0	blue	100 m spool	8	39.8	14.6	EN 564 ⚠	€€ 1019

ROPE ACCESSORIES		CODE	COLOR	MATERIAL	Length cm in	WEIGHT gloz
DEFENDER 	Has capacity for two or more ropes. Protects rope sheath against abrasion on rough surfaces and edges. Has capacity for two or more ropes.	W1027B080	black	Cortex	80 32	✗
		W1027BI20			120 47	
ROPE PROTECTOR 	Protects rope sheath against abrasion on rough surfaces and edges.	W8100B050	various	PVC	50 20	✗
		W8100B070			70 28	
		W8100BI00			100 39	
		W8100BI20			120 47	
EDGE ROLLER 	Compact light edge roller for rope protection. Protects a moving rope against the abrasion. Basic set consists of 3 modules and 4 maillons.	K0050OS03	orange + silver	aluminium alloy	✗	777 27.41
		K0050OS01				232 8.18
ATIKA 	Very stable rope protector with rubber layer on the lower side eliminates unwanted movement. Ensures safe work at height and load lifting over sharp edges.	RK900PP00	silver	stainless steel + rubber	✗	1450 51
THERMOCUTTER 	Electric thermo-cutter is ideal machine for cutting the ropes and accessory cords.	X0004GB00	green	✗	✗	✗
ROPEMARKER 	Marker for climbing and working equipment.	X0015XX00	black	✗	✗	✗







CARABINERS

LIGHT ALLOY
QUICKDRAWS
STEEL
ACCESSORY



Singing Rock produces the most common and used carabiners which you can use for your climbing activities. HMS carabiners for belay devices, belaying with Munter hitch and other use. Lightweight and durable quickdraws for sport, trad and ice climbing. Oval carabiners designed to use mainly at anchor points, pulleys or ascenders. D carabiners which keep the slings or belay devices in a right load direction. All of them manufactured using the latest technologies (Key-lock, Hot forging, unique product number) to ensure long-lasting quality and ideal weight-strength ratio.



KEYLOCK

for easy manipulation

Keylock is an extremely simple and ingenious locking system that solves the problems associated with the traditional design of carabiners. It eliminates any risk of ropes or slings becoming entangled in the gate or in the carabiner nose when it is being connected or released. Neither the gate, which is completely cylindrical, nor the nose has any sharp edges. Ropes and slings do not, therefore, come into the contact with any cutting edges.



SERIAL UNIQUE NUMBER

identification of metal parts

For better traceability and inspection recording the Singing Rock metal parts are marked with the serial unique number.



HOT FORGING

The latest technology in manufacturing carabiners, where the aluminum alloy is heated to reach very plastic state when being forged, in other words when it takes the final shape. This allows the metal to be formed more easily and to be moved to the areas where it is needed and removed from the areas where it is not necessary. Compared to the cold forged carabiners, hot forged can provide better strength/weight ratio and resistance.

SCREW LOCK



TWL- TWIST LOCK



TRIPLE LOCK

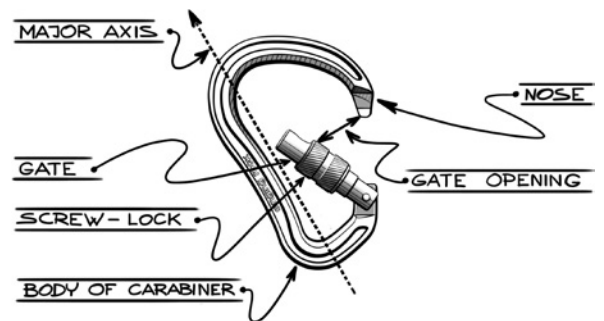
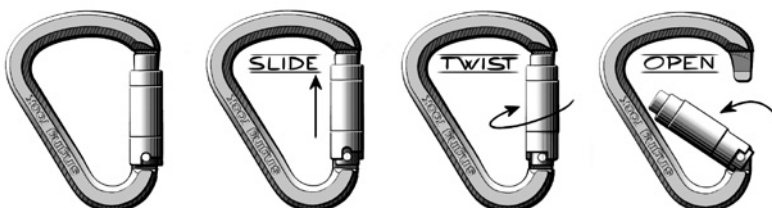



LIGHT ALLOY CARABINERS		CODE	COLOR	WEIGHT gloz	STRENGTH MAJOR AXIS kN	STRENGTH MINOR AXIS kN	STRENGTH OPEN GATE kN	GATE OPENING (d) mm	STANDARDS	CE
HECTOR BC triple lock 	Large versatile pear-shaped HMS carabiner with triple lock gate and removable captive bar designed especially as a fixed connector in anchor systems or lanyards.	K012IEC00	blue matt	91 3.21	30	9	8	26	EN 12275 EN 362	CE 1019
		K012IBC00	black matt							
HECTOR triple lock 	Large versatile pear-shaped HMS carabiner with triple lock gate designed for multiple uses mainly for belaying or anchoring when working at heights.	K012IEE00	blue matt	89 3.14	30	9	8	26	EN 12275 EN 362	CE 1019
		K012IBB00	black matt							
HECTOR BC screw 	Large versatile pear-shaped HMS carabiner with screw gate and removable captive bar designed especially as a fixed connector in anchor systems or lanyards.	K0114EC00	blue matt	85 3.00	30	9	8	26	EN 12275 EN 362	CE 1019
		K0114BC00	black matt							
HECTOR screw 	Large versatile pear-shaped HMS carabiner with screw gate designed for multiple uses mainly for belaying or anchoring when working at heights.	K0114EE00	blue matt	83 2.93	30	9	8	26	EN 12275 EN 362	CE 1019
		K0114BB00	black matt							
BORA triple lock 	Universal HMS carabiner for climbing and working at heights with triple lock safety.	K0119EE00	orange matt	68 2.40	23	8	8	22	EN 12275 EN 362	CE 1019
		K0119BB00	black matt							
BORA TWL 	Versatile HMS locking biner designed for belaying, rappelling and anchor building with twist lock gate.	K0108EE00	grey matt	68 2.40	23	8	8	22	EN 12275 EN 362	CE 1019
		K0108BB00	black matt							
BORA screw 	Versatile HMS locking biner designed for belaying, rappelling and anchor building.	K0107EE00	orange matt	63 2.22	23	8	8	22	EN 12275 EN 362	CE 1019
		K0107BB00	black matt							
BORA GP screw 	HMS carabiner designed specifically to eliminate the dangers of cross loading.	K0107EP00	grey matt	64 2.26	23	8	8	22	EN 12275 EN 362	CE 1019
		K0107BP00	black matt							
COLT screw 	Our smallest lightweight screw carabiner. Ideal for traditional and alpine climbing.	K0112EE00	silver matt	48 1.69	26	8	11	18	EN 12275 EN 362	CE 1019
		K0112BB00	black matt							
COLT screw 3PACK 	Three light and small locking carabiners for anchoring on trad and alpine climbing at a reduced price.	K0112XX30	silver matt	48 1.69	26	8	11	18	EN 12275 EN 362	CE 1019
COLT straight 	Full size hot-forged carabiner with solid gate. This real all-round biner is engineered to be equally used for both sport and trad climbing.	K0111EE00	grey matt	42 1.48	26	8	11	21	EN 12275	CE 1019
		K0111BB00	black matt							
COLT bent 	Full size hot-forged carabiner with solid gate. This real all-round biner is engineered to be equally used for both sport and trad climbing.	K0110EE00	yellow matt	42 1.48	26	8	11	21	EN 12275	CE 1019
		K0110BB00	black matt							
COLT WIRE bent 	Lightweight carabiner with wire lock designed to be used for sport and traditional climbing as well as ice climbing.	K0120EE00	blue matt	36 1.27	23	8	11	22	EN 12275 EN 362	CE 1019
COLT WIRE straight 	Lightweight carabiner with wire lock designed to be used for sport and traditional climbing as well as ice climbing.	K0113EE00	silver matt	36 1.27	26	8	11	22	EN 12275	CE 1019



LIGHT ALLOY CARABINERS		CODE	COLOR	WEIGHT g/oz	STRENGTH MAJOR AXIS kN	STRENGTH MINOR AXIS kN	STRENGTH OPEN GATE kN	GATE OPENING (d) mm	STANDARDS	€€
VISION straight		K0009EE00	brown	36 1.16	25	7	8	19	EN 12275 ⚙️	€€ 1019
VISION bent		K0025EE00	red	36 1.16	25	7	8	19	EN 12275 ⚙️	€€ 1019
VISION STRAIGHT 6PACK		K0009EE60	mix	36 1.16	25	7	8	19	EN 12275 ⚙️	€€ 1019
OXY triple lock		K0122EE07	gold	81 2.86	26	8	7	21	EN 12275 EN 362	€€ 1019
		K0122BB07	black							
OXY TWL		K0122EE06	gold	81 2.86	26	8	7	21	EN 12275 EN 362	€€ 1019
		K0122BB06	black							
OXY screw		K0122EE05	gold	74 2.61	26	8	7	21	EN 12275 EN 362	€€ 1019
		K0122BB05	black							
OXY BC triple lock		K0123EC07	gold	83 2.93	26	8	7	21	EN 12275 EN 362	€€ 1019
		K0123BC07	black							
OXY BC TWL		K0123EC06	gold	83 2.93	26	8	7	21	EN 12275 EN 362	€€ 1019
		K0123BC06	black							
OXY BC screw		K0123EC05	gold	76 2.68	26	8	7	21	EN 12275 EN 362	€€ 1019
		K0123BC05	black							
OZONE triple lock		K0018AA00	blue	85 3.00	26	9	7	21	EN 12275 EN 362	€€ 1019
		K0018BB00	black matt							
OZONE TWL		K0017AA00	blue	85 3.00	26	9	7	21	EN 12275 EN 362	€€ 1019
		K0017BB00	black matt							
OZONE screw		K0016AA00	blue	80 2.82	26	10	7	21	EN 12275 EN 362	€€ 1019
		K0016BB00	black matt							
VIA FERRATA		K5330PE	carabiner polished, gate yellow elox	90 3.17	30	8	9	21	EN 12275	€€ 0333
PALM		K0124SY09	light grey with black + yellow gate	117 4.13	28	7	14	28	EN 362/T EN 12275/K ⚙️	€€ 1019
		K0124ST09	light grey with black + grey gate							



QUICKDRAWS		CODE	COLOR	WEIGHT g/oz	LENGTH cm	STRENGTH SLING	STRENGTH MAJOR AXIS kN	STRENGTH MINOR AXIS kN	STRENGTH OPEN GATE kN	GATE OPENING (d) mm	STANDARDS	CE
	Full-size hot-forged durable quickdraw with solid gates intended for sport climbing.	K6715E011	grey + yellow	99 3.49	12	22	26	8	11	21	EN 12275 EN 566	CE1019
	Full size hot forged durable quickdraw with solid gates intended for sport climbing overhanging routes.	K6715E017	grey + yellow	102 3.60	17	22	26	8	11	21	EN 12275 EN 566	CE1019
	Super versatile quickdraw with a snag free Keylock carabiner on the top and a smooth-clipping wire carabiner on the bottom.	K6716E011	grey + blue	93 3.28	12	22	26	8	11	21	EN 12275 EN 566	CE1019
	Lightweight full-size quickdraw engineered to be equally used for trad, alpine and ice climbing.	K6613E011	silver + blue	79 2.79	11	22	26	8	11	22	EN 12275 EN 566	CE1019
	Full-size hot-forged durable quickdraw with solid gates intended for sport climbing.	K6719E016	grey + yellow	99 3.49	11	22	26	8	11	21	EN 12275 EN 566	CE1019
	Super versatile quickdraw with a snag free Keylock carabiner on the top and a smooth-clipping wire carabiner on the bottom.	K6720E016	grey + blue	93 3.28	11	22	26	8	11	21	EN 12275 EN 566	CE1019
	Full-size quickdraw engineered to be equally used for trad, alpine and ice climbing.	K6721E016	silver + blue	83 2.93	11	22	26	8	11	21	EN 12275 EN 566	CE1019
	Our lightest quickdraw, the ideal partner for lightweight style.	K6604E011	brown + red connector, strop mix	75 2.65	11	22	25	7	8	19 (both carabiners)	EN 12275 EN 566	CE1019
	Six full-size hot forged durable COLT quickdraws with solid gates intended for sport climbing at a reduced price.	K6715E611	grey + yellow	99 3.49	12	22	26	8	11	21	EN 12275 EN 566	CE1019
	The ideal set for hard core sport climbers working on overhanging routes. Six full size hot forged durable COLT 17 CM quickdraws at a reduced price.	K6715E617	grey + yellow	102 3.60	17	22	26	8	11	21	EN 12275 EN 566	CE1019
	Six full-size hot-forged durable COLT 16 quickdraws with solid gates intended for sport climbing at reduced price.	K6719E616	grey + yellow	99 3.49	11	22	26	8	11	21	EN 12275 EN 566	CE1019
	Six super versatile quickdraws with a snag free Keylock carabiner on the top and a smooth-clipping wire carabiner on the bottom, an reduced price pack.	K6720E616	grey + blue	93 3.28	11	22	26	8	11	21	EN 12275 EN 566	CE1019
	Six full-size quickdraws engineered to be equally used for trad, alpine and ice climbing at reduced price.	K6721E616	silver + blue	83 2.93	11	22	26	8	11	21	EN 12275 EN 566	CE1019
	Ultra light set of six VISION quickdraws for lightweight style at a reduced price	K6604E611	brown + red	75 2.65	11	22	22	5	8	19	EN 12275 EN 566	CE1019

QUICKDRAWS		CODE	COLOR	WEIGHT gloz	LENGTH cm	STRENGTH SLING	STRENGTH MAJOR AXIS kN	STRENGTH MINOR AXIS kN	STRENGTH OPEN GATE kN	GATE OPENING (d) mm	STANDARDS	CE
ARTWALL SET 	Steel quickdraw mainly made for longterm placement in the climbing gyms.	K695013	grey + black	225 7.94	13	22	30	10	10	25	EN 12275 EN 566	CE 1019
		K695016		228 8.04	16							
		K695020		232 8.18	20							
		K695030		238 8.40	30							
		K695060		260 9.17	60							
QUICKDRAW RUBBER FIX 11 mm 	Ideal for fixing the carabiner to the quickdraw sling.	C0084XX11	black	×	×	×	×	×	×	×	×	×
QUICKDRAW RUBBER FIX 16 mm 	Ideal for fixing the carabiner to the quickdraw sling.	C0084XX16	black	×	×	×	×	×	×	×	×	×

STEEL CARABINERS		CODE	COLOR	WEIGHT gloz	STRENGTH MAJOR AXIS kN	STRENGTH MINOR AXIS kN	STRENGTH OPEN GATE kN	GATE OPENING (d) mm	STANDARDS	CE
ARTWALL 	Steel carabiner specially designed for long-term placement in the climbing gyms.	K4310PP00	silver	130 4.59	30	10	10	25	EN 12275	CE 1019
OVAL STEEL CONNECTOR TRIPLE LOCK 	Steel connector for permanent anchor points and work at heights.	K4241ZO07	zinc plated	195 6.88	30	9	8	18	EN 362	CE 1019
OVAL STEEL CONNECTOR screw 	Steel connector for permanent anchor points and work at heights.	K4241ZO05	zinc plated	176 2.68	30	9	8	18	EN 362	CE 1019
D STEEL CONNECTOR TRIPLE LOCK 	Extra strong steel connector for permanent anchor points and work at heights.	K4081ZO	zinc plated	267 9.42	50	13	20	25	EN 362	CE 1019
D STEEL CONNECTOR screw 	Extra strong steel connector for permanent anchor points and work at heights.	K4080ZO	zinc plated	255 8.99	50	13	20	25	EN 362	CE 1019

STEEL MAILLONS		CODE	COLOR	WEIGHT gloz	STRENGTH MAJOR AXIS kN	STRENGTH MINOR AXIS kN	DIAMETER mm	GATE OPENING (d) mm	STANDARDS	CE
MAILLON MINI OVAL 	Steel oval mini maillon with a diameter of 6 mm. Not intended for securing people!	K82006Z	zinc plate	35 1.23	20	×	6	7.5	×	×
MAILLON SMALL OVAL 	Small steel oval maillon with a diameter of 8 mm.	K82008Z	zinc plate	77 2.72	35	10	8	11	EN12275 EN 362 ⚠️	CE 0082
MAILLON SMALL DELTA 	Small steel delta maillon with a diameter of 7 mm. Not intended for securing people!	K82207Z	zinc plate	58 2.05	4	×	7	11	×	×
MAILLON BIG DELTA 	Steel delta maillon with a diameter of 10 mm.	K82210Z	zinc plate	153 5.40	45	10	10	12	EN12275 EN 362 ⚠️	CE 0082



STEEL MAILLONS		CODE	COLOR	WEIGHT g/oz	STRENGTH MAJOR AXIS kN	STRENGTH MINOR AXIS kN	DIAMETER mm	GATE OPENING (d) mm	STANDARDS	€
MAILLON BIG D		K82310Z	zinc plate	153 5.40	45	10	10	10	EN12275 EN 362 O MA	€ 0082
MAILLON BIG SQUARE		K82410Z	zinc plate	166 5.86	45	10	10	12	EN12275 EN 362 O MA	€ 0082
MAILLON BIG TWIST		K82508Z	zinc plate	106 3.74	32	10	8	17.5	EN12275 EN 362 O MA	€ 0082

ACCESSORY CARABINERS		CODE	COLOR	WEIGHT g/oz	STRENGTH MAJOR AXIS kN	GATE OPENING (d) mm	MATERIAL
PORTER		K9000BB03	black	32 1.13	X	23	plastic
MINI PEAR		K5052EE00	various	16 0.56	X	11	light-alloy
MINI D		K5182EE00	various	25 0.88	X	14	light-alloy
MINI D screw		K0027YX00	bronze	28 1.00	3	12	light-alloy
		K0027BY00	black				
MINI D screw 40PACK		K0027BY40	black, bronze	1238 43.7	3	12	aluminium-alloy











THE NEW SHEETS



RECOMMENDED USE OF SINGING ROCK HELMETS

PRODUCT NAME	SPORT CLIMBING	TRAD CLIMBING, BIG WALL	GLACIER TRAVEL, CLASSIC MOUNTAINEERING	TECHNICAL MOUNTAINEERING, ICE CLIMBING	VIA FERRATA	SKITOURING*, EXPEDITIONS	ROPE COURSES, RENTALS	CANYONING, SPELEO
PENTA 	+++	++++	++++	++++	++++	+++	++	+
PENTA JUNIOR 	+++	++++	++++	+++	++++	++	+++	+
HEX 	++	++++	++++	+++	++++	++	++++	++

++++ THE BEST +++ MORE SUITABLE ++ SUITABLE + LESS SUITABLE × UNSUITABLE

* none of the Singing Rock helmets are certified according to EN 1077

Head protection is one of the main principles of the movement outdoors where there is a risk of fall of any object from a height. Whether you are in a mountainous terrain or in the crags, you will always appreciate a light and durable climbing helmet with an innovative design. Singing Rock helmets are produced by two different constructions:



PENTA construction:
In-mold – EPS foam liner injected under a thin PC shell

Advantages of this construction:

- lightweight and low profile of the helmet
- lightweight, comfortable and easy size adjustment system with the straps

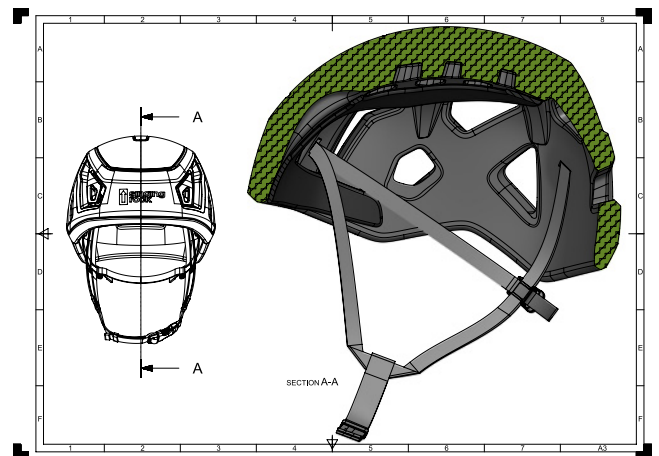

HEX construction:
ABS hard shell + EPP foam liner

Advantages of this construction:

- durability of the helmet, shell protects against falling objects and guarantees a high degree of protection against impact force, including repeated impact force
- easy and quick size adjustment mechanism in the back of the helmet (similar to cycling helmets)

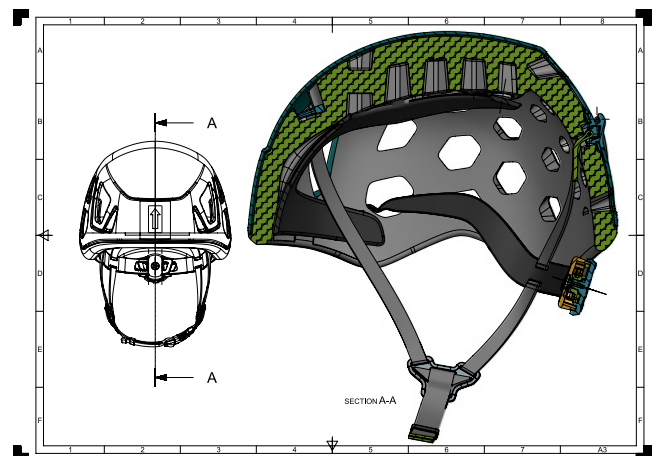

Notes:

ABS – acrylonitrile butadiene styrene

EPP – expanded polypropylene

EPS – expanded polystyrene

PC – polycarbonate

HELMETS		CODE	COLOR	SIZE	WEIGHT gloz	HEAD CIRCUM- FERENCE cm	CHIN STRAP DURABILITY	ELECTRICAL DURABILITY	LOW TEM- PERATURE DURABILITY	VENTILA- TION	DURABILITY FOR LATERAL DEFORMA- TION	SIDE IMPACT FORCE	MATERIAL	STANDARDS	CE
PENTA <p>The second generation of the popular, lightweight, comfortable and ventilated climbing helmet.</p>	C0091YX02	yellow gold	S	185 6.53	48-54	min. 50 kg	✘	-10 °C	✓	✘	✓	36 % PC, 34 % EPS, 19 % PA, 5 % POM, 5 % PE foam, 1 % rubber	EN 12492	CE	
	C0091YX04		M/L	195 6.88	52-58										
	C0091YX05		XL	205 7.23	56-62										
	C0091GX02	mint green	S	185 6.53	48-54										
	C0091GX04		M/L	195 6.88	52-58										
	C0091GX05		XL	205 7.23	56-62										
	C0091SX02	olive green	S	185 6.53	48-54										
	C0091SX04		M/L	195 6.88	52-58										
	C0091SX05		XL	205 7.23	56-62										
	C0091FX02	spruce blue	S	185 6.53	48-54										
C0091FX04	M/L		195 6.88	52-58											
C0091FX05	XL		205 7.23	56-62											
PENTA JUNIOR <p>Lightweight, comfortable and fully ventilated helmet for the smallest climbers.</p>	C0091JY02	arnica yellow / dark teal	UNI	185 6.53	48-54	min. 50 kg	✘	-10 °C	✓	✘	✓	36 % PC, 34 % EPS, 19 % PA, 5 % POM, 5 % PE foam, 1 % rubber	EN 12492	CE	
HEX <p>Durable, fully ventilated helmet suitable for both sport and trad climbing, via ferrata or rope parks.</p>	C0900YX03	arnica yellow	M	300 10.58	52-58	min. 50 kg	✘	-10 °C	✓	✘	✓	49 % ABS, 29 % EPP, 10 % PA, 3 % POM, 3 % TPU, 3 % PE foam, 1 % PA 30 GF, 1 % steel, 1 % rubber	EN 12492	CE	
	C0900YX04		L	330 11.64	55-61										
	C0900RX03	fox red	M	300 10.58	52-58										
	C0900RX04		L	330 11.64	55-61										
	C0900AX03	mountain lake azure	M	300 10.58	52-58										
	C0900AX04		L	330 11.64	55-61										
	C0900MX03	garish blue	M	300 10.58	52-58										
	C0900MX04		L	330 11.64	55-61										
	C0900WX03	ice white	M	300 10.58	52-58										
	C0900WX04		L	330 11.64	55-61										

HELMET ACCESSORIES		CODE	COLOR	SIZE	WEIGHT gloz	MATERIAL
HEX PADDING <p>Replacement padding for the helmet with easy maintenance and replacing.</p>	C0901SB03	gray	M	10 0.35	PES	
	C0901SB04		L			
PENTA PADDING <p>Replacement padding for the helmet with easy maintenance and replacing.</p>	C0092XX02	gray	S	10 0.35	PES	
	C0092XX03		M/L			
	C0092XX05		XL			









ICE AXES



RECOMMENDED USE OF SINGING ROCK ICE AXES

PRODUCT NAME	GLACIER TRAVEL, CLASSIC MOUNTAINEERING	TECHNICAL MOUNTAINEERING, ICE CLIMBING	DRYTOOLING	SKITOURING, EXPEDITIONS
BANDIT 	+	++++	++	+
EDGE 	++	+++	x	+
WIZARD 	++++	x	x	+++
WIZARD LIGHT 	+++	x	x	++++
MERLIN 	++++	x	x	++

++++ THE BEST +++ MORE SUITABLE ++ SUITABLE + LESS SUITABLE x UNSUITABLE

Singing Rock offers you classic mountaineering ice axes for summiting snow-covered peaks, glacier tours or skitouring. Also technical ice axes for ice climbing and technical mountaineering. All ice axes are made in the Czech republic with 100% guarantee of quality and safety.



Type of ice axe

In terms of standards, ice axes are divided into two types: Type 1 and Type 2. These types make a distinction between basic (B) and technical (T) ice axe.

Type 1 ice axe

These ice axes have a lower strength requirement, generally they are used for skitouring, glacier travel and classic mountaineering. For Type 1 ice axes, no marking is required. If there is any, usually there is B marking as "basic".

Type 2 ice axes

These ice axes have a high strength requirement. Generally are used for ice climbing, dry tooling and technical mountaineering. For Type 2 ice axes the marking is required as T marking "technical".

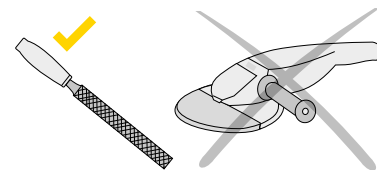
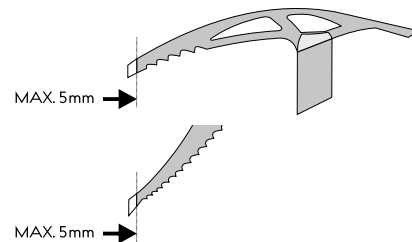
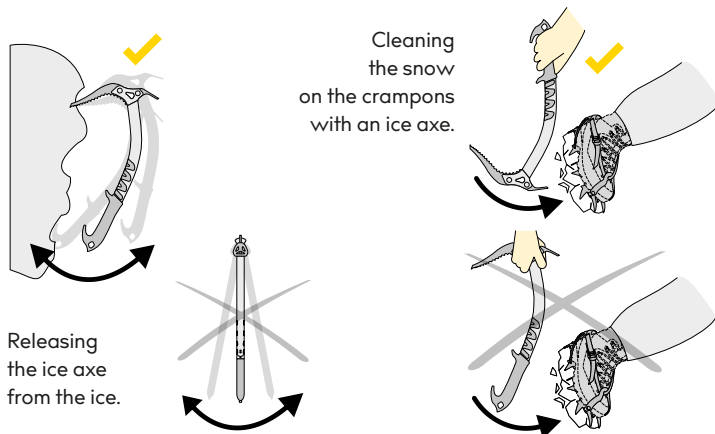



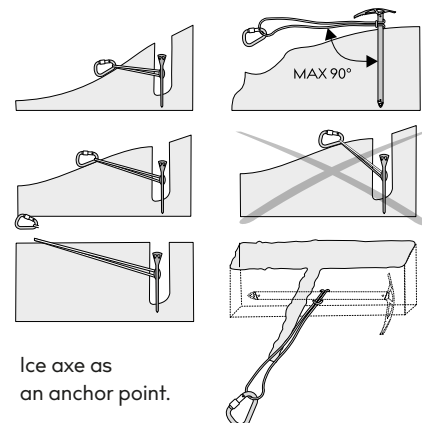

For sharpening the pick we recommend to use a fine manual file. Do not sharpen the pick using a mechanical grinder.







Ice axe as an anchor point.



ICE AXES		CODE	VERSION	WEIGHT gloz	Pick type	SHAFT TYPE	MATERIAL	STANDARD	€€
BANDIT 	Ice axe designed especially for climbing difficult icefalls and technically demanding routes.	RK003YX00H	50 cm/hammer	610 21.52	2 (T)	2 (T)	50 % CrMo steel, 40 % Al alloy, 9 % plastic, 1 % stainless steel	EN 13089	€€1019
		RK004YX00A	50 cm/adze						
EDGE 	Lightweight ice axe for technical mountaineering. Compromise between classical ice axe and modern technical tool.	RK009AX00H	54 cm/hammer	555 19.58	2 (T)	2 (T)	55 % CrMo steel, 40 % Al alloy, 4 % plastic, 1 % stainless steel	EN 13089	€€1019
		RK008AX00A	54 cm/adze						
WIZARD 	Ice axe designed for traditional alpine mountaineering.	RK005TX055	55 cm	479 16.90	X	1 (B)	50 % CrMo steel, 40 % Al alloy, 9 % plastic, 1 % stainless steel	EN 13089+A1	€€1019
		RK005TX062	62 cm	508 17.92					
		RK005TX069	69 cm	537 18.98					
WIZARD LIGHT 	Our lightest ice axe designed especially for ski touring, altitude climbing and all adventures where every gram counts.	RK006WX052	52 cm	380 13.40	X	1 (B)	50 % CrMo steel, 40 % Al alloy, 9 % plastic, 1 % stainless steel	EN 13089+A1	€€1019
		RK006WX059	59 cm	405 14.29					
MERLIN 	Ice axe designed for glacier tours and easy snow ascents in the mountains.	RK007BX058	58 cm	455 16.05	X	1 (B)	50 % CrMo steel, 40 % Al alloy, 9 % plastic, 1 % stainless steel	EN 13089+A1	€€1019
		RK007BX065	65 cm	480 16.93					
		RK007BX072	72 cm	505 17.81					

ICE AXE ACCESSORIES		CODE	COLOR	WEIGHT gloz	NUMBER OF PARTS
HAMMER 	Spare hammer for BANDIT and EDGE ice axes.	RK105BB000	black	44 1.55	1
ADZE 	Spare adze for BANDIT and EDGE ice axes.	RK106BB000	black	49 1.73	1
PICK SPACER 	Adze/hammer replacement for BANDIT or EDGE.	RK113BB000	black	12 0.42	1
ICE PICK 	Pick for BANDIT ice axe for ice climbing.	RK107BB000	black	133 4.69	1
DRY PICK 	Pick for drytooling designed for BANDIT ice axe.	RK108BB000	black	139 4.90	1
MASS 	Stainless steel extra weights for stronger swing for BANDIT ICE PICK.	RK115XX000	silver	50 1.76	pair
EDGE PICK 	Ice pick for EDGE ice axe.	RK116XX000	black	116 4.09	1
GRIP STICKER 	Adhesive non-slip tape for all models of ice axes.	RK114BB000	black	2 0.07	1
BOXER 	Finger protector for BANDIT ice axe.	RK109BB000	black	10 0.35	1
RHINO 	Finger rest for ice axe BANDIT.	RK110BB000	black	7 0.25	1

ICE AXES ACCESSORIES		CODE	COLOR	WEIGHT gloz	STRENGTH	LENGTH cm (INCL. CARABINERS)	MATERIAL
BUNGEE	 Lightweight tether for leashless climbing, attaches ice tools to the harness.	RK112WX000	white/yellow	90 3.17	300 kg	80-135	35% PAD, 5% elastic fiber, 60% light alloy
BUNGEE SINGLE	 Lightweight tether for attaching ice tools to the harness.	RK117WX000	white/yellow	47 1.66	300 kg	85-145	35% PAD, 5% elastic fiber, 60% light alloy
BUNGEE 360°	 Lightweight swivel tether for leashless climbing, attaches ice tools to the harness.	RK118WX000	white/yellow	110 3.88	300 kg	80-135	25% PAD, 5% elastic fiber, 70% light alloy
FIX	 Simple leash with minimal weight suitable for MERLIN and WIZARD ice axes.	RK111BY000	black+ yellow	24 0.85	max. load 100 kg	✘	PAD
FIX PLUS	 Advanced leash with padding and easy releasing/ tightening system suitable for EDGE and WIZARD ice axes.	RK111BY001	black+ yellow	39 1.38	max. load 100 kg	✘	PAD













CRAMPONS



RECOMMENDED USE OF SINGING ROCK CRAMPONS

PRODUCT NAME	GLACIER TRAVEL, CLASSIC MOUNTAINEERING	TECHNICAL MOUNTAINEERING, ICE CLIMBING	DRYTOOLING	SKITOURING, EXPEDITIONS
LUCIFER III Tech 	+	++++	+++	+
FAKIR III Classic 	++++	+	x	++
FAKIR III Semi-classic 	++++	+	x	+++
FAKIR III Tech 	+++	++	x	++++

++++ THE BEST +++ MORE SUITABLE ++ SUITABLE + LESS SUITABLE x UNSUITABLE

If you go for an easy glacier walk or demanding alpine ascent or event to the Himalaya expedition, Singing Rock crampons are designed for your most common activities in the world of the snow and ice. Made in the Czech republic with 100% guarantee of quality and safety.

CLASSIC SINGING ROCK CRAMPONS BINDING SYSTEMS

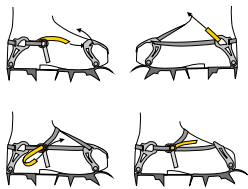

SEMI-CLASSIC

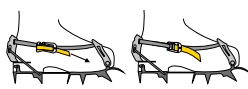
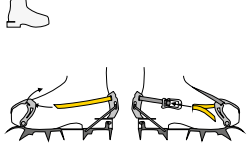

TECH

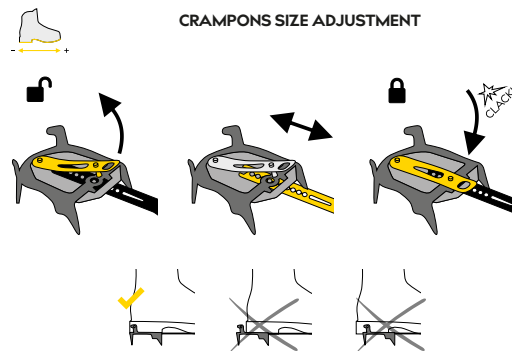
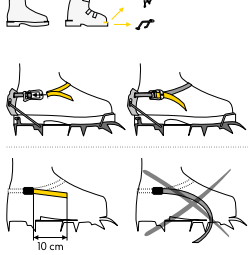

The size of the crampons is easy to adjust by locking metal sheet. When putting the crampons onto the boots, make sure to put left and right crampon on. Always check if the crampons are secured tightly.

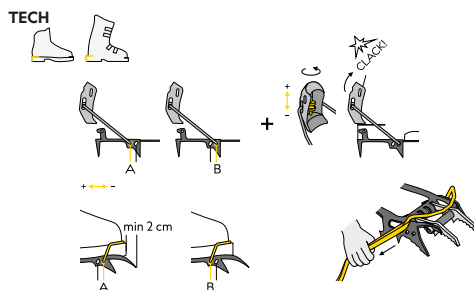

SHARPENING THE FRONT POINTS

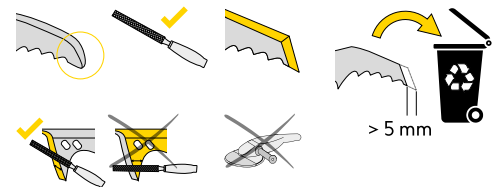

For sharpening the front points we recommend to use a fine manual file. Do not sharpen the front points using a mechanical grinder.

Crampons with binding system „Classic“ should be fixed on trekking boots by straps. Crampons with binding system „Semi-classic“ and „Tech“ should be fixed on suitable trekking/climbing boots by a quick release system.



Skitouring at Kaprun, Austria • © Jan Zahula



CRAMPONS		CODE	VERSION	WEIGHT gloz	NUMBER OF SPIKES	FRONT SPIKES	SIZE EU	MATERIAL	STANDARD	€€
	Lightweight and versatile chromoly crampons with replaceable front points. Designed for climbing steep icefalls, difficult mixed routes and mountaineering.	RK207AX00T	tech	880 31.04	12	2	37-47	60 % CrMo steel, 20 % TPU, 15 % stainless steel, 5 % PAD	EN 893	€€
	All-round twelve-points crampons for classic mountaineering. Designed especially for glacier tours and steep snow slopes.	RK206AX00C	classic	810 28.57	12	2	37-47	60 % CrMo steel, 20 % TPU, 15 % stainless steel, 5 % PAD	EN 893	€€
	All-round lightweight twelve-points crampons for classic mountaineering. Designed for all terrain from glacier tours to steep snow slopes or classic ice couloirs.	RK206AX00S	semi-classic	900 31.75	12	2	37-47	60 % CrMo steel, 20 % TPU, 15 % stainless steel, 5 % PAD	EN 893	€€
	All-round lightweight twelve-points crampons for classic mountaineering. Designed for all terrain from glacier tours to steep snow slopes or classic ice couloirs.	RK206AX00T	tech	880 31.04	11/12	1/2	37-47	60 % CrMo steel, 20 % TPU, 15 % stainless steel, 5 % PAD	EN 893	€€



CRAMPONS ACCESSORIES		CODE	SIZE	COLOR	WEIGHT gloz	NUMBER OF PARTS
	Anti-snow plates made of softer plastic for better efficiency and lifetime.	RK607AX000		blue	70 2.47	pair
	Anti-snow plates made of softer plastic for better efficiency and lifetime.	RK608AX000		blue	74 2.61	pair
	Set of replaceable front points.	RK609YY000		black	23 0.81	4
	Center bar for Singing Rock crampons FAKIR III and LUCIFER III.	RK610XX02	S (EU 35-45)	black	92 3.25	pair
		RK610XX03	M/L (EU 37-47)		100 5.53	
		RK610XX05	XL (43-53)		115 4.06	
	Flexible center bar improves walking comfort and increases a lifetime of crampons FAKIR III used with flexible boots.	RK611XX02	S (EU 35-45)	silver	75 2.65	pair
		RK611XX03	M/L (EU 37-47)		80 2.82	
		RK611XX05	XL (EU 43-53)		90 3.17	
	Accessory front crampon bail for boots with a welt only on the heel. Compatible with Tech variants of all generations of FAKIR and LUCIFER crampons.	RK612XX000			66 2.33	pair
	Accessory front crampon bail for ski touring boots. Compatible with Tech variants of all generations of FAKIR and LUCIFER crampons.	RK613XX000			40 1.41	pair
	Anti-snow plates made for Fakir II crampons.	RK601YY000		yellow	94 3.32	pair
	Anti-snow plates for Lucifer II crampons.	RK602YY000		yellow	86 3.03	pair
	Set of replaceable front points for Lucifer II crampons	RK605BB000		black	32 1.13	4
	Long connecting part for Fakir II and Lucifer II crampons (EU 43-52) also suitable for telemark or skitouring boots.	RK606BB005		black	60 2.12	pair
	Protective and storage bag for your crampons.	RK251XX000		black	188 6.63	PVC









ICE SCREWS



RECOMMENDED USE OF SINGING ROCK ICE SCREWS

PRODUCT NAME	GLACIER TRAVEL, CLASSIC MOUNTAINEERING	TECHNICAL MOUNTAINEERING, ICE CLIMBING	SKITOURING, EXPEDITIONS
SPIN 	++++	+	+++
QUICKSPIN 	+++	++++	++

++++ THE BEST +++ MORE SUITABLE ++ SUITABLE + LESS SUITABLE × UNSUITABLE

STRENGTH OF THE ICE SCREWS

SPIN and QUICKSPIN ice screws correspond to the standard EN 568:2015. The strength of anchoring of the screw in ice is very closely associated with the quality and structure of the ice, the outdoor temperature and the experience of the climber screwing in the screws.

The strength values given on the basis of certification are valid only for the strength of the screw itself. The strength of the anchoring of the screw in ice is almost always lower than given on the certificate.

For greater safety in the case of a possible fall we recommend the use of shock absorbers reducing dynamic load. Other components to be used in conjunction with this product should be appropriate CE certified mountaineering equipment.

NOTIFICATION: L 12 cm ice screws do not comply with the requirement for strength in ice pursuant to the standard EN 568:2015. They have a short length. However, in practice they are often essential.

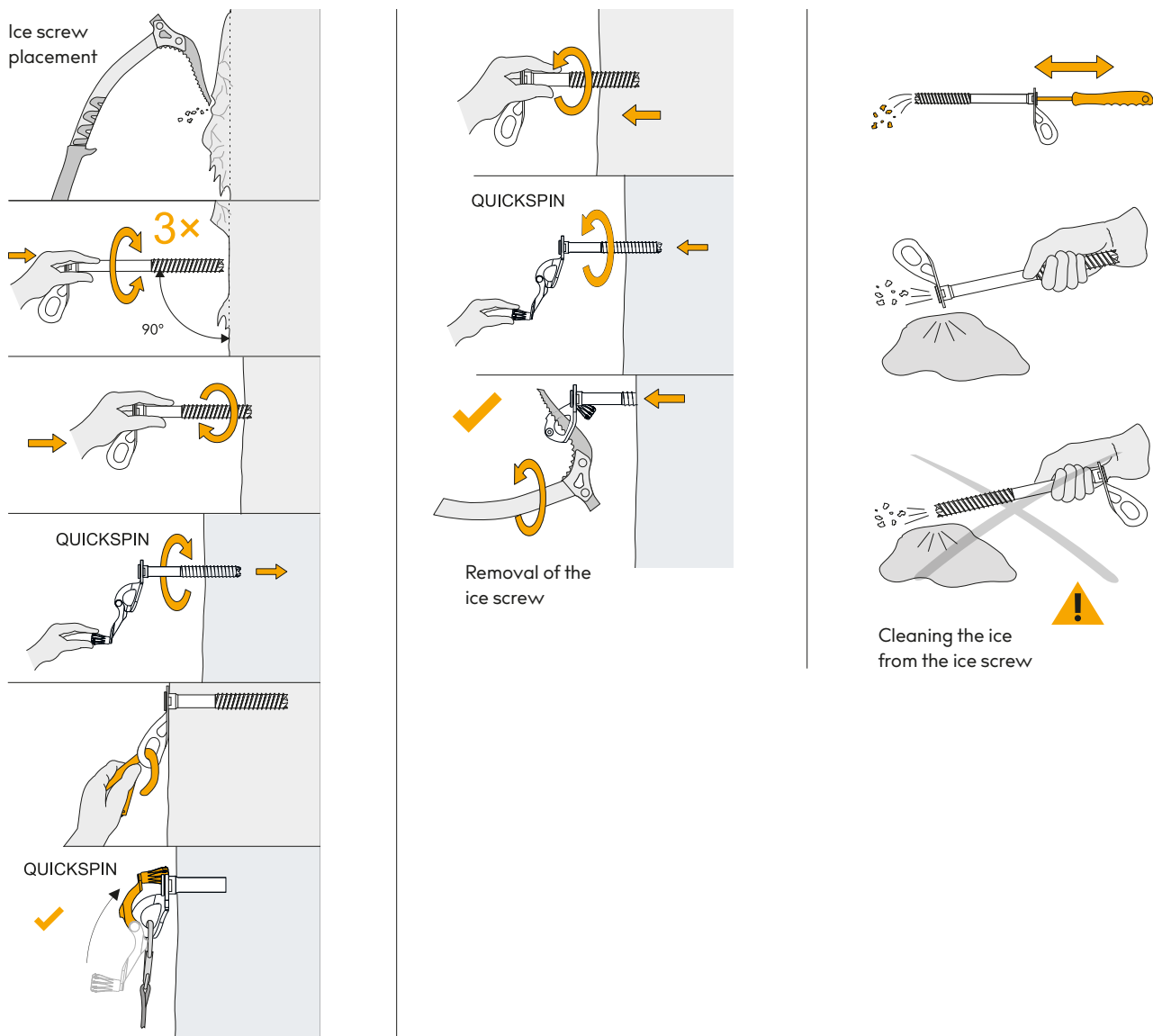

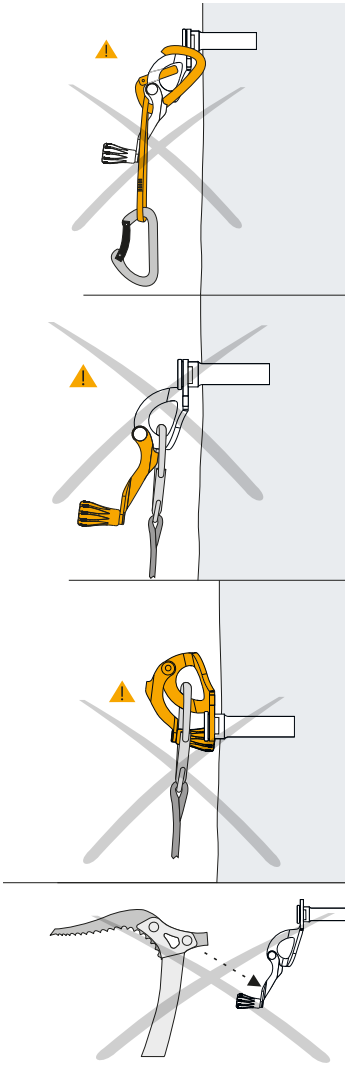

Wrong use of the ice screw with the quickdraw

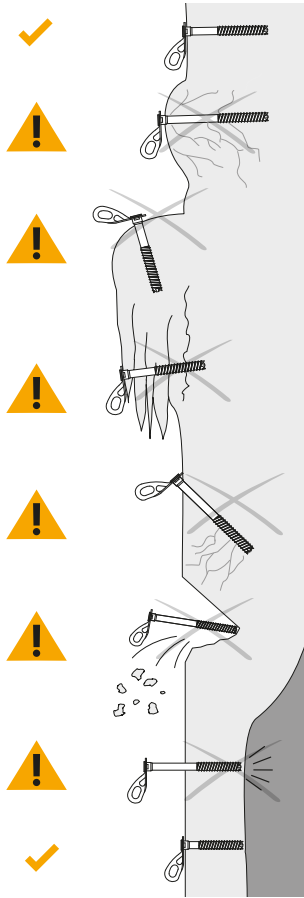

Recommended and wrong ice screw placements

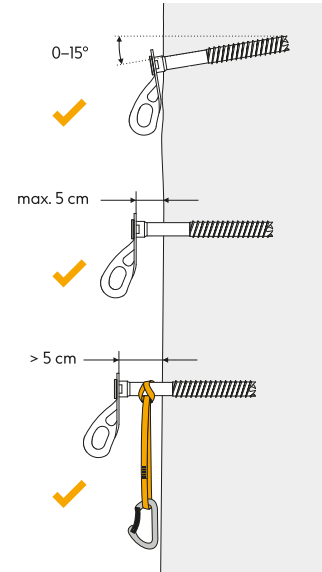

Angles and lengths of the proper ice screw placement

ICE SCREWS		CODE	LENGHT	WEIGHT glöz	MATERIAL	STANDARD	CE
SPIN 	Hardened steel ice screw with a light alloy hanger ideal for glacier tours and classic alpine climbs.	RK302SX012	120 mm	100 3.53	CrMo steel with anti-corrosion coating, light alloy	✗	✗
		RK302SX017	170 mm	125 4.41		EN 568	CE 1019
		RK302SX022	220 mm	150 5.29		EN 568	CE 1019
QUICKSPIN 	Hardened steel ice screw with a light alloy hanger and a folding crank intended for ice climbing and technical mountaineering.	RK303SX012	120 mm	115 4.06	CrMo steel with anti-corrosion coating, light alloy, PAD	✗	✗
		RK303SX017	170 mm	135 4.76		EN 568	CE 1019
		RK303SX022	220 mm	160 5.64		EN 568	CE 1019

ICE SCREWS ACCESSORIES		CODE	COLOR	WEIGHT glöz	MATERIAL	PARAMETER
ICE SCREWS BAG 	Lightweight and convenient roll-up bag to protect and organize your ice screws of the length 12–22 cm.	RK351XX000	black	150 5.29	PVC	28 x 12 x 9 cm
ICE SCREW COVER 	Soft plastic slip-on cap to protect sharp teeth of ice screws. Sold in a package of 5 pcs.	RK352XX000	black	4 0.14	plastic	30 mm length, 20 mm diameter





BELAY DEVICES

ASCENDERS
DESCENDERS



Singing Rock produces two types of belay devices:

RAMA – belay device with enhanced braking feature

The principle of RAMA belay device is when the climber falls, the device pushes on the carabiner, the rope tightens and blocks the rope. Even that it is belay device with enhanced braking feature, your brake hand must never let go of the rope.

To give a slack, your brake hand pushes the rope towards the device, your other hand pulls the rope through the device.

To take a slack, pull the climber's rope and pull the brake hand through the device. Never let go brake hand off the rope.

To lower the climber, the belayer pushes on the nose or body of the belay device without letting go of the brake hand on the rope.

Advantages of RAMA belay device:

- enhanced braking feature in case of the climber fall
- designed for sport climbing on single pitch routes and gym climbing
- functionality is according to the tube principle and is therefore easy to use for lead and top-rope climbing

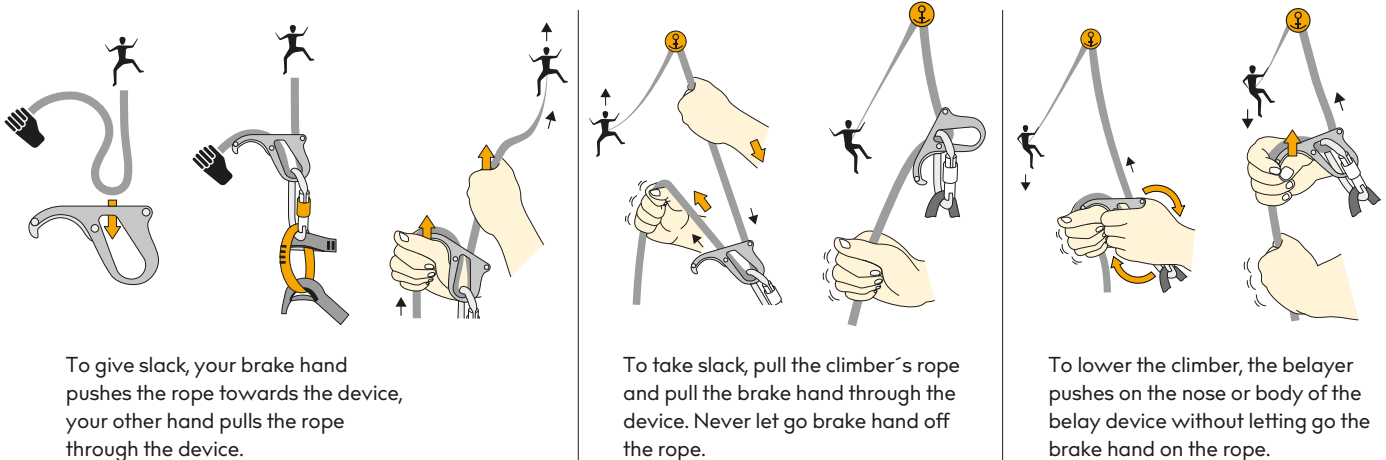

SHUTTLE, BUDDY – rappel/belay devices





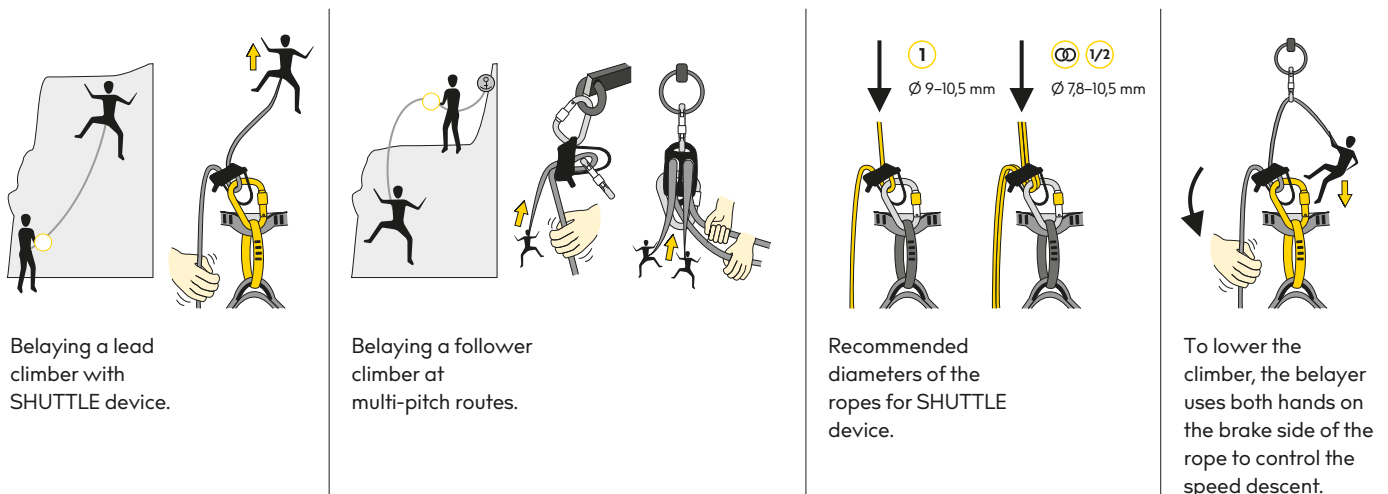

The principle of SHUTTLE, BUDDY devices is when the climber falls, the brake hand grips the rope and pulls it downward, the rope gets pressed into the grooved channels, thus increasing the friction until the rope stops. Braking efficiency of the belay device depends on many different factors, such as: diameter and type of the rope, wear of the rope, the way of handling etc. To achieve sufficient braking efficiency during rappelling or belaying, grip the rope firmly (with your thumb towards the belay device) and keep your brake hand below the belay device.



Advantages of SHUTTLE, BUDY belay devices:

- simple, compact and lightweight device
- compatible for single, twin and half dynamic ropes
- designed for belaying and rappelling on single or multi-pitch routes





BELAY DEVICES		CODE	COLOR	WEIGHT gloz	STRENGTH kN	DIAMETER OF ROPES mm	MATERIAL	STANDARD	CE
RAMA 	Intuitive belay device with an enhanced braking feature designed for gym or single pitch sport climbing.	K0043OX00	orange	84 2.96	x	8,7-11	light alloy, stainless steel, plastic	EN 15151-2	x
		K0043SX00	grey						
RAMA SET 	Intuitive RAMA belay device with an enhanced braking feature and oval OXY carabiner with twist gate lock. Ideal set for gym or single pitch sport climbing.	M0201XX00	grey / gold	165 5.82	carabiner 26 kN	8,7-11	light alloy, stainless steel, plastic		CE1019
FIGURE 8 L 	Belay and rappel device of classic proven shape with wide range of rope diameters 8.5-13 mm.	K603IEE	variable (red, yellow or titanium)	125 4.41	30	8,5-13	light alloy	EN 15151-2	x
		K603IBB	black matte						
FIGURE 8 M 	Belay and rappel device of classic proven shape with wide range of rope diameters 7.5-11 mm.	K602IEE	variable (red, yellow or titanium)	104 3.67	25	7,5-11	light alloy	EN 15151-2	x
		K602IBB	black matte						
SHUTTLE 	Belay and rappelling device for ropes with a diameter of 7.8-10.5 mm.	K6140EE00	bordo	65 2.29	x	7,8-10,5	light alloy	EN 15151-2	x
		K6140BB00	black matte						
BUDDY 	Belay tube for use with ropes of diameter 7.8-11 mm.	K6132BB	black matte	54 1.90	x	7,8-10,5	light alloy	EN 15151-2	x
		K6132EE	yellow or red						
BUDDY SET 	Light and compact BUDDY tube and BORA GP HMS screw gate carabiner for belaying in the gyms or crags.	M0200XX00	yellow / grey	119 4.20	carabiner 23 kN	7,8-10,5	light-alloy	EN 15151-2 EN12275 EN 362	CE1019

DESCENDERS		CODE	COLOR	WEIGHT gloz	DIAMETER OF ROPES mm	MATERIAL	STANDARD	CE
DOUBLE STOP PLUS 	Descender with anti-panic system in case of accidental loss of descent control.	K031DSD00	black	421 4.85	9-12	mechanism: stainless steel, lever: light alloy with plastic cover, body: light alloy	EN 12841 - Typ C	CE0123
INDY EVO PLUS 	Manually operated descender device with double auto-locking system.	K010IBX00	black	480 16.93	10-12	aluminium, stainless steel, plastic	EN 341 / 2A (Ø 11 mm) EN 12841 / C (Ø10-12 mm) NFPA-L (Ø10-13 mm)	CE0426
SIR 	Robust multipurpose device for use in industrial rope access.	K032SIR00	black body, yellow lever	365 12.87	9-12	mechanism: stainless steel, lever: light alloy, body: light alloy	EN 341-A EN 12841-C EN 795-B (s Lanyardem WP) ANSI Z359.7	CE0123

ASCENDERS		CODE	COLOR	WEIGHT gloz	PARAMETER	DIAMETER OF ROPES mm	MATERIAL	STANDARD	CE
LIFT 	Hand ascenders for safe and smooth ascent.	RK804BX0R	black	190 6.70	right	8-13	body: light alloy, cam: stainless steel, trigger: plastic	EN 567 EN 12841 typ B	CE1019
		RK804BX0L		190 6.70	left				
FOOT LIFT 	Foot ascender to improve rope ascending in rope access.	RK807BX0L	black	160 5.64	left	8-13	light alloy, steel, plastic, PA	x	x
		RK807BX0P		160 5.64	right				
CAM CLEAN 	Compact and lightweight chest ascender for safe and smooth ascent, rescue and special rope techniques.	RK805BX00	black matte	125 4.41	x	8-13	body: light alloy, cam: stainless steel, trigger: plastic	EN 567 EN 12841 typ B	CE1019
STRAP FOR CAM CLEAN 	Strap for CAM CLEAN chest ascender fixation with a plastic cover which protects a harness from wear by the ascender.	W0085BB00	black	10 0.35	x	x	x	x	x







ROCK CLIMBING GEAR



Singing Rock pulleys of different structures will come in handy for rescue, hauling heavy loads or tightening a Tyrolean traverse. Manufactured in the Czech republic using the latest technologies to ensure long-lasting quality and maximum strength.

WLL – Working Load Limit

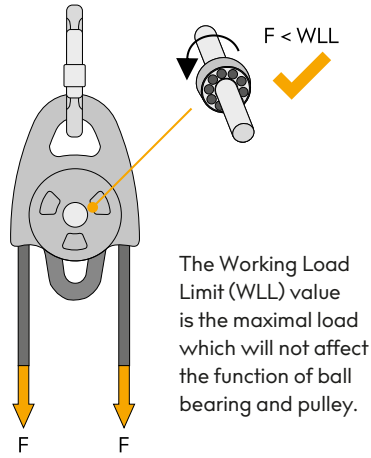



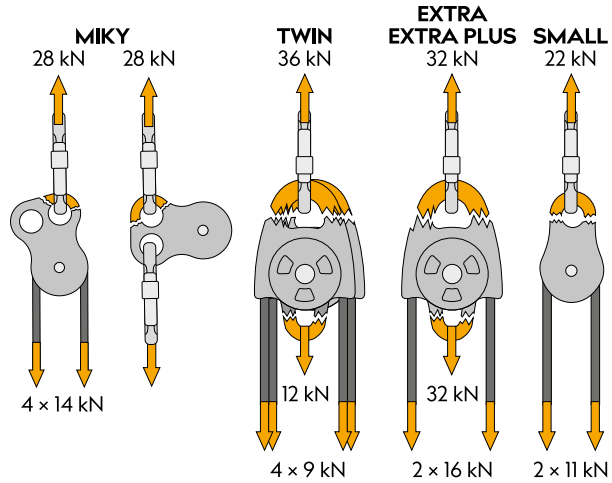

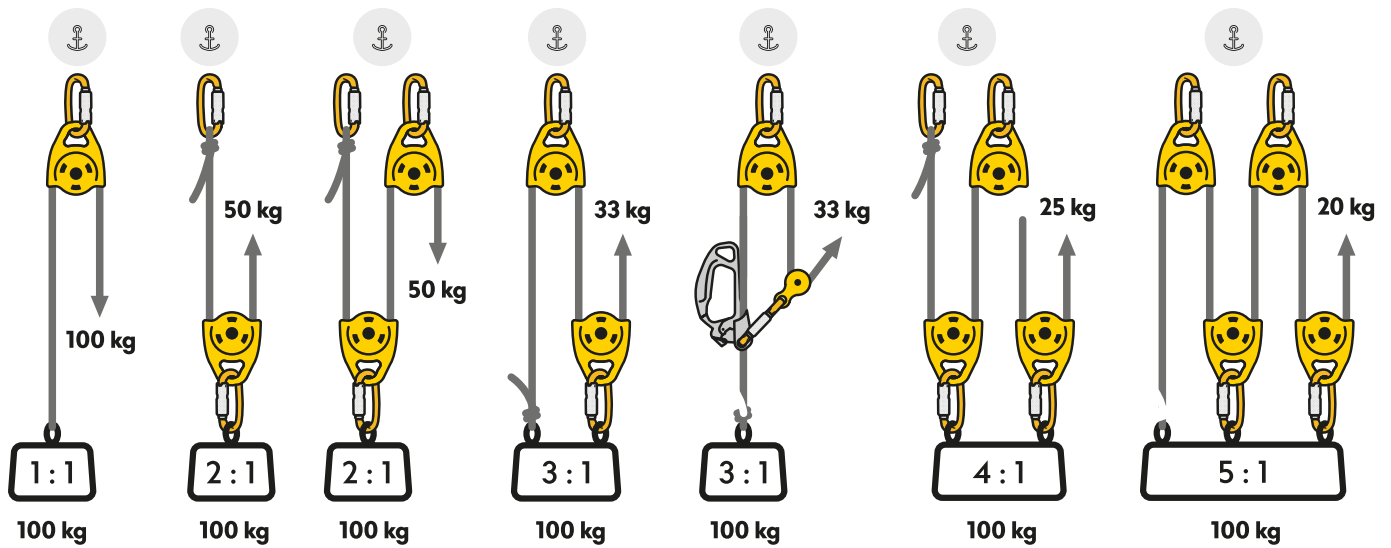

Breaking load



Hauling systems





PULLEYS		CODE	COLOR	WEIGHT g/oz	BEARING	MAX. DIA- METER OF ROPE mm	STRENGTH kN	WORKING LOAD kN	EFFICIENCY %	MATERIAL	STANDARD	€
PULLEY SMALL 	Small pulley for those who occasionally need to build simple hauling systems or manipulate with the objects. Essential gear for glacier tours in case of crevasse rescue.	RK800EE00	orange	92 3.25	friction	13	22	2x2,5	81	sheave and side plates – aluminum alloy, bearing – bronze, axle – stainless steel	EN 12278	€1019
		RK800BB00	black									
PULLEY EXTRA 	Large pulley for those who need great hauling efficiency, durability and light weight.	RK801EE00	orange	257 9.07	sealed ball	13	32	2x3	94	sheave and side plates – aluminum alloy, bearing – steel, axle – stainless steel	EN 12278	€1019
		RK801BB00	black									
PULLEY EXTRA PLUS 	Large pulley for those who need great hauling efficiency, durability and light weight	RK808OS00	orange	276 9.74	sealed ball	13	32	2x3	94	sheave and side plates – aluminum alloy, bearing – steel, axle – stainless steel	EN 12278	€1019
		RK808BB00	black									
TWIN PULLEY 	Large twin pulley for those who need great hauling efficiency and durability.	RK802BB00	black	421 14.85	sealed ball	13	36	4x3	94	sheaves and side plates – aluminum alloy, bearings – steel, axle – stainless steel	EN 12278	€1019
		RK802EE00	orange									
MIKY PULLEY 	Lightweight pulley with two attachment holes. Designed for tree climbing application. Suitable for use with Prusik friction knot.	RK806BB00	black	105 3.70	friction	13	28	2x2,5	81	sheave and side plates – aluminum alloy, bearing – bronze, axle – stainless steel	EN 12278	€1019
TANDEM PULLEY 	Double pulley for Tyrolean traverses and zip-lines with two stainless steel sheaves.	RK803BB00	black	290 10.23	sealed ball bearings	13	25	4x2,5	✗	side plates – al. alloy, sheaves and axles – stainless steel, bearings – steel	EN 12278	€1019







HARDWARE

ANCHOR POINTS
PITONS



PERMANENT ANCHOR POINTS INSTALLATION

If you are doing the first ascent or replacing the old fixed pro our hanger plates with bolt or glue ins will come handy. Make sure that you install them properly.

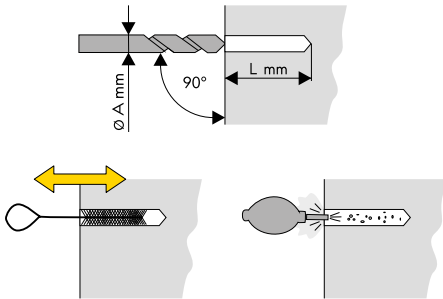

Drilling:

Make a hole with diameter and deepness as indicated in the instruction of use of each anchor device. Clean the hole with a brush and then with an air, being sure that there are no residues.

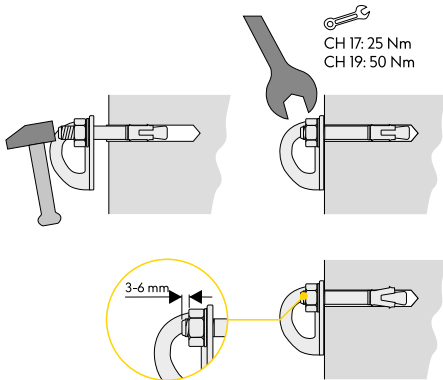

UPAT UPM 44
FIS 360 V

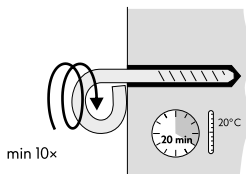
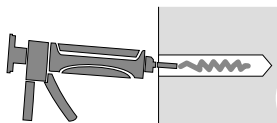

Hanger plate with bolt installation:

Insert the hanger plate to the bolt. Hammer the assembly into the pre-drilled hole. Check if the hanger touches the rock/structure surface with its whole area and tight the nut. If using other than original bolt, make sure, it is strong enough and compatible with the hanger.

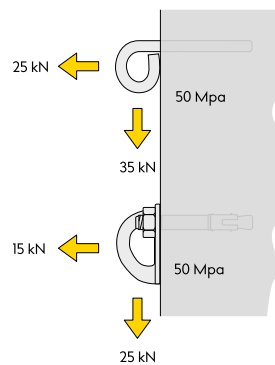
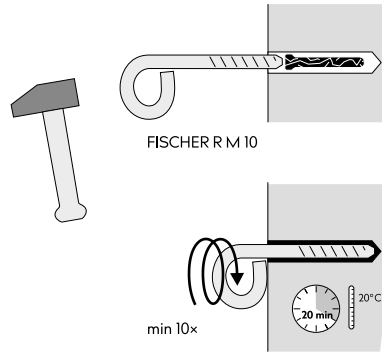

Glue-in anchor installation:

Fill the hole halfway with glue or use capsule and break it using the anchor. Insert the glue-in anchor and turn it about ten times so that the double component glue is mixed well. Wait for the glue to harden before loading the glue-in anchor. Singing Rock recommends use this type of glue: UPM 44 or FIS 360V or alternatively resin capsule RM10.

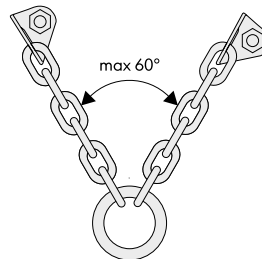

DISTRIBUTION OF FORCES AT THE BELAY STATION

With increasing an angle the balance of forces acting on the belay station anchor points changes. When connecting the individual protection points we ensure distribution of load and weight which impact the belay station.

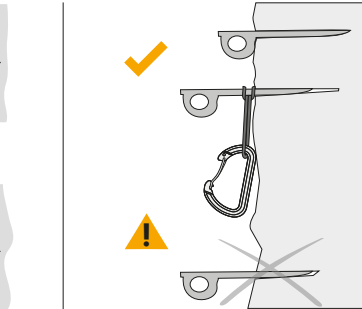





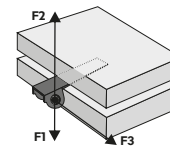



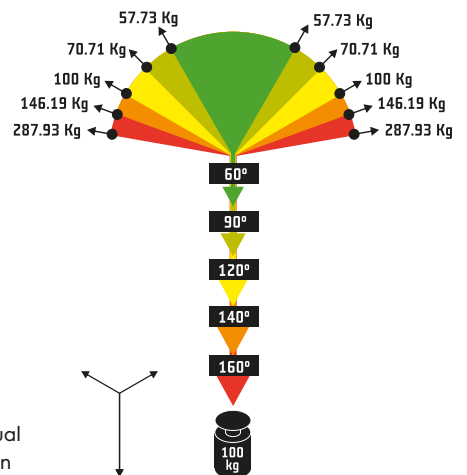

PITON STRENGTH:

PITON spikes conform to EN 569:2007 standard. The strength of a piton driven in the rock is very closely connected with quality and structure of the rock surface, weather conditions and experiences of the climber who drives the piton in. The strength of an anchored piton is almost always lower than specified in the certificate. The tearing strength and load-carrying capacity of a rock piton driven in the rock decreases over time. Repeated driving of the spike in and out reduces its strength. We classify pitons into "safety pitons" S which show high strength and have a length of at least 90 mm and "progression pitons" P which, in contrast to safety pitons, have lower strength.



	F1	F2	F3
S	25 kN	10 kN	15 kN
P	12.5 kN	5 kN	7.5 kN



ANCHOR POINTS		CODE	WEIGHT g/oz	DIAMETER mm	STRENGTH MAJOR AXIS K _n	STRENGTH MINOR AXIS kN	LENGHT OF BOLT mm	DEPTH OF THE HOLE mm	THICKNESS mm	MATERIAL	STANDARD	CE
HANGER PLATE WITH BOLT 	Stainless steel hanger plates with bolt for permanent anchor point.	RK715XX10	112 3.95	10	25	15	84	75	3	A4 stainless steel	EN 795 EN 959	X
		RK715XX12	140 4.94	12								
HANGER PLATE WITH BOLT 	Zinc coated steel hanger plates with bolt for permanent anchor point.	RK716XX10	100 3.53	10	25	15	84	75	4	zinc-coated steel	EN 795 EN 959	X
		RK716XX12	125 4.41	12								
HANGER PLATE STAINLESS STEEL 	Stainless steel hanger plates for permanent anchor point for bolts with diameter 10 and 12 mm.	RK702XX10	42 1.48	10	25	X	X	X	3	stainless steel	EN 959 EN 795 typ B	X
		RK702XX12		12								
HANGER PLATE ZINC COATED 	Zinc-coated steel hanger plates for permanent anchor point and bolts with diameter 10 and 12 mm.	RK704XX10	62 2.19	10	25	X	X	X	4	zinc-coated steel	EN 959 EN 795 typ B	X
		RK704XX12		12								
GLUE IN ANCHOR 	Stainless steel durable permanent anchor point.	RK703XX10	120 4.23	12	30	25	80	X	10	stainless steel	EN 795 EN 959	X
RAPPELING STATION 12 mm 	Zinc-coated rappelling station for the climbing gyms or crags.	RK500XX00	580 20.46	12	25	X	X	X	X	zinc-coated steel	EN 795 EN 959	X
RIGGING PLATE 1/3 	Device for multi-point anchoring, provides efficient force distribution at different load directions.	RK713BB00	65 2.29	X	36	X	X	X	6	light alloy	X	CE 1019
RIGGING PLATE 3/5 	Device for multi-point anchoring, provides efficient force distribution at different load directions.	RK714BB00	145 5.11	X	50	X	X	X	8		X	CE 1019
TWISTER 	Rotating anchor device to prevent twisting of other system components.	K0030OG00	88 3.10	X	22	X	X	X	X	light alloy, stainless steel	EN 354	CE 2777
REDBLOCK 	Stainless steel anchor device, that extends the lifetime of the rope when top roping.	K0006RP00	375 13.23	max Ø of rope 12 mm	26	X	X	X	X	side plates - light alloy, sheave - stainless steel	X	CE 1019

PITONS AND HOOKS		CODE	WEIGHT g/oz	LENGHT cm	WIDTH mm	STRENGTH kN	MATERIAL	STANDARD	€€
PITON A3 	Hardened steel piton for thinner cracks.	RK708XX03	50 1.76	3	3	✗	Cr-Mo hardened steel	EN 569	€€ 1019
		RK708XX05	54 1.90	5					
		RK708XX07	58 2.05	7					
PITON A5 	Hardened steel piton for medium-width cracks.	RK709XX05	88 3.10	5	5	✗	Cr-Mo hardened steel	EN 569	€€ 1019
		RK709XX07	98 3.46	7					
		RK709XX09	103 3.63	9					
PITON V 	Hardened steel V piton for larger cracks and pockets.	RK710XX08	85 3.00	8	8-13	✗	Cr-Mo hardened steel	EN 569	€€ 1019
		RK710XX10	100 3.53	10					
		RK710XX12	130 4.59	12					
ROCK HAMMER 	Classic rock hammer for big wall climbing, first ascents or work at height.	RK750XX00	590 20.81	29,5	✗	✗	head and tube Cr-Mo steel, handle rubber	✗	✗
ULTIMA 	Special piton which makes the unclimbable passages possible to climb. For thin cracks up to 2,5 mm wide.	RK706XX00	21 0.74	✗	✗	5	Cr-Mo hardened steel blade, stainless steel wire	✗	✗
CAPTAIN 	Hook for small to medium flakes, edges and rugosities.	RK705XX00	46 1.62	13	✗	✗	Cr-Mo steel, polyamide	✗	✗
SENTINEL 	Hook for fragile edges and drilled holes.	RK711XX00	43 1.52	13	✗	✗	Cr-Mo steel, polyamide	✗	✗





CLIMBERS

Adéla Dudíková, Agrodolce 6b, Cinque Torri, Italy • Jan Zámečník



SLINGS

QUICKDRAW SLINGS
ACCESS SLINGS
WEBBINGS



Whether made of polyamide or Dyneema®, textile slings are an essential part of the climbing equipment. Singing Rock slings are suitable for creating a belay station, protection or as an aid sling for rope ascent. Made in the Czech republic with 100 % guarantee of quality and safety for your climbing activities.

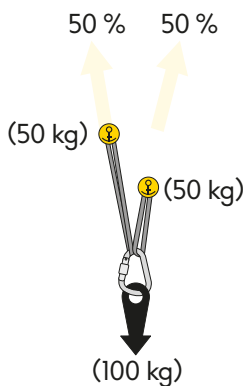
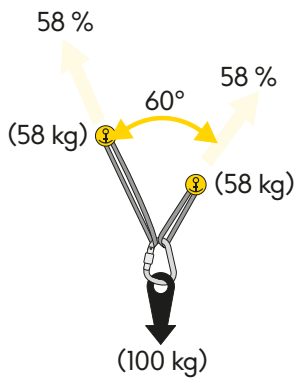
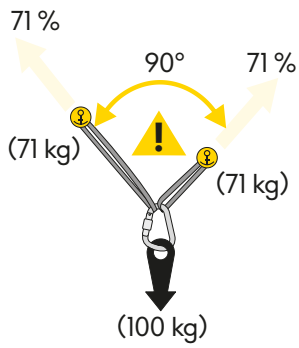
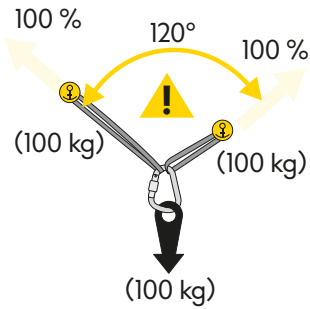

MBS (Minimum Breaking Strength) = 22 kN



100 % MBS

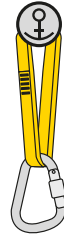

~200 % MBS



~200 % MBS

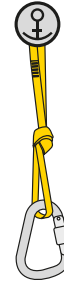

~50 % MBS

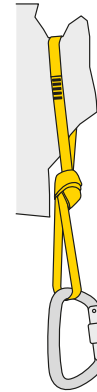
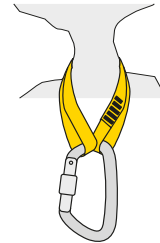
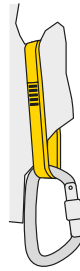
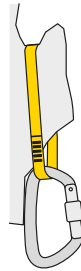

Minimum Breaking Strength can be increased when the sling is doubled and also is decreased when the sling is used with a knot.

DISTRIBUTION OF FORCES AT THE BELAY STATION

With increasing an angle the balance of forces acting on the belay station anchor points changes. When connecting the individual protection points we ensure distribution of load and weight which impact the belay station. At the same time we ensure the functionality of the belay station in case of failure of one of the protection points.



Mirek Matějec, Jižní cesta Vllc, Prachovská jehla, Czechia







Jan Zamečník

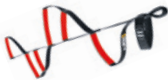

SLINGS		CODE	COLOR	WEIGHT g/oz	LENGTH cm	LENGTH DEVIATION	STRENGTH	MATERIAL	STANDARD	CE
SLING 16 mm 	Polyamide sling 16 mm wide with a strength of 22 Kn.	C2075X060	yellow	48 1.69	60	± 2 cm	22	PAD	EN 566	CE1019
		C2075X080	blue	60 2.12	80					
		C2075X120	red	86 3.03	120	-2/+4 cm				
		C2075X150	black	107 3.77	150					
		C2075X240	blue	174 6.14	240					
DYNEEMA® SLING 11 mm 	Dyneema® sling for multipurpose use when climbing.	C2001X030	white/yellow	15 0.53	30	± 2 cm	22	Dyneema®	EN 566	CE1019
		C2001X060	white/blue	27 0.95	60					
		C2001X080	white/red	33 1.16	80	-2/+4 cm				
		C2001X120	white/black	49 1.73	120					
		C2001X150	white/yellow	61 2.15	150					
DYNEEMA® SLING 8 mm 	Dyneema® sling for multipurpose use when climbing.	C2004X060	yellow/white	20 0.71	60	± 2 cm	22	Dyneema®	EN 566	CE1019
		C2004X120	red/white	35 1.23	120	-2/+4 cm				

QUICKDRAW SLINGS		CODE	COLOR	WEIGHT g/oz	LENGTH cm	STRENGTH kN	MATERIAL	STANDARD	CE
QUICKDRAW SLING 16/25 mm 	Vari-width quickdraw sling for your own quickdraw customization.	C2087X012	yellow	12 0.42	12	22	PAD	EN 566	CE1019
		C2087X017	yellow	18 0.63	17				
		C2087A012	blue	12 0.42	12				
QUICKDRAW SLING 16 mm 	Sling for a quickdraw set.	C2085X011	black	12 0.42	11	22	PAD	EN 566	CE1019
		C2085X013		14 0.49	13				
		C2085X016		15 0.53	16				
		C2085X020		18 0.63	20				
		C2085X030		25 0.88	30				
DYNEEMA QUICKDRAW SLING 11 MM 	Sling for a quickdraw set, ideal for your own easy quickdraw customization or the replacement of the worn sling.	C2000X011	blue	7 0.25	11	22	Dyneema®	EN 566	CE1019
		C2000X013		8 0.28	13				
		C2000X016		9 0.32	16				
		C2000X020		11 0.39	20				
		C2000X030		15 0.53	30				
QUICKDRAW SLING BLACK ARROW 	Polyamide quickdraw sling especially suitable for climbing gyms with a width of 20 mm.	C2002B013	black	18 0.63	13	22	PAD	EN 566	CE1019
		C2002B016		20 0.71	16				
		C2002B020		23 0.71	20				
		C2002B030		30 0.81	30				

WEBBINGS		CODE	COLOR	WEIGHT g/m	LENGTH m	WIDTH mm	STRENGTH kN	MATERIAL	STANDARD	CE
TUBULAR WEBBING 	20 mm tubular webbing for various applications with a strength of 17 kN.	C0037RR00	red	39,4	120	20	17	low stretch PAD	EN 565	CE1019
		C0037BB00	black	38,2		20	16			
FLAT WEBBING 	16 mm flat strap for various applications with a strength of 15 kN.	C0035A.O00	white/black	37,7	120	16	15	low stretch PAD	EN 565	CE1019
SLACKLINE WEBBING 	Ideal webbing for all kind of slackline.	C0065BY00	yellow/black	59	150	25	30	low stretch PES	×	×

ACCESS SLINGS		CODE	COLOR	WEIGHT glaz	LENGTH cm	STRENGTH kN	MAX. LOAD kg	MATERIAL	STANDARD	€€
JACOB DYNEEMA		C2151BY00	red with white	140 4.94	140	22	×	Dyneema®	EN 354 EN 566	€€ 1019
JACOB		C2150BY	black with red	210 7.41	150	×	500 (max. load for a loop 100 kg)	PAD, plastic	×	×
SAFETY CHAIN		C2419X120	black / white	102 3.60	120	sling 22, single loops 3.5	×	PAD	EN 566 ⚠	€€ 1019
		C2419X140	black / white	117 4.13	140					
		C2419B120	black	102 3.60	120					
		C2419B140	black	117 4.13	140					
LOOP CHAIN		C2088WY00	white / yellow	75 2.65	100	22	×	Dyneema®, PAD, PES	EN 566 ⚠	€€ 1019
REGULATOR		C2152BR00	antracit / red	90 3.17	18-136	×	150	webbing PAD, buckle steel	×	×
FOOTER II		W1024BX00	black with red	115 4.06	40-140	×	150	PAD	×	×
FOOTER II COMPLETE		W1025BX00	black with red	145 5.11	40-140	×	150	PAD	×	×
FOOTER XP		W1051BX00	black with red	90 3.17	30-170	×	180	PAD, light alloy	×	×







VIA FERRATA SETS



If you enjoy climbing via ferrata, Singing Rock PHARIO fall absorbers will help you to climb the biggest challenges. PHARIO fall absorbers are designed for children and adults weighing between 40 and 120 kg. PHARIO can be easily attached to all kinds of harnesses used on via ferratas or in rope parks.

50,000 extensions. That's how many our elastic arms must meet to keep you safe on via ferratas.

It's better not to fall on via ferrata, but when you do, you'll find a fall indicator label inside the protective case to show you if the shock absorber has already been activated and needs to be replaced.



Ergonomically shaped, lightweight, easy to use keylock PALM carabiners with wear indicator fit perfectly in your hand. When the wear of the carabiner is below the mark line on the carabiner you should replace the carabiners.

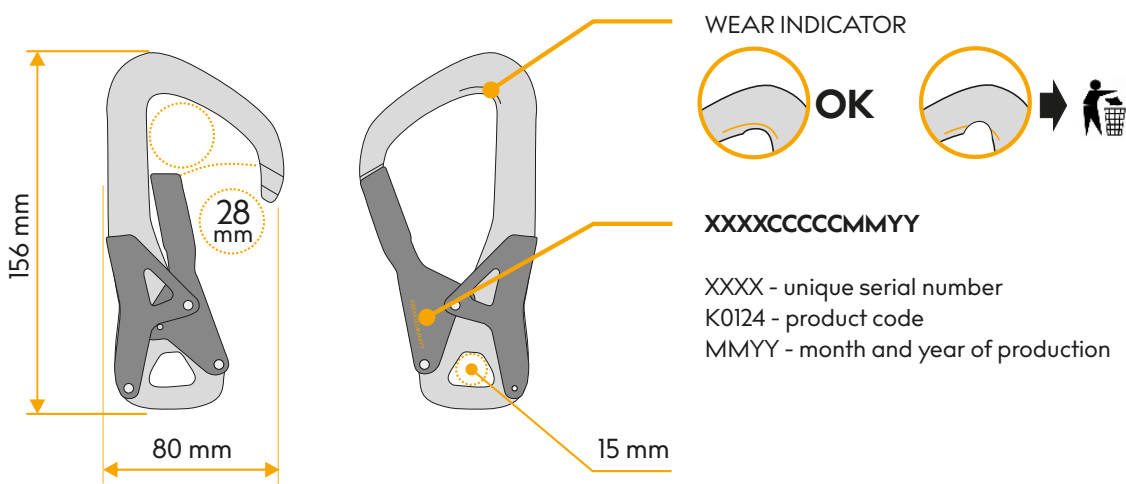



VIA FERRATA SETS

		CODE	COLOR	WEIGHT gloz (incl. carabiners)	STANDARD	€
PHARIO LITE 	Compact lightweight shock absorber with elastic arms for via ferrata.	C2319YB00	black/ice grey	400 14.11	EN 958:2017 EN 12275 ⚙️	€1019
PHARIO 360° 	Shock absorber with stainless steel swivel and elastic arms for via ferrata routes, rope courses and adventure parks.	C2318YB00	black/lemon	485 17.11	EN 958:2017 EN 12275 ⚙️	€1019
PHARIO PALM 	Energy absorber for via ferrata routes, ropes courses and adventure parks with palm Keylock carabiners.	C2317YB00	black/lemon	500 17.64	EN 958:2017 EN 12275 ⚙️	€1019

VIA FERRATA PACKETS

		CODE	SIZE	WEIGHT gloz	WAIST SIZE cm in	LEG LOOPS cm in	CHEST WIDTH cm in	STANDARD	€
FERRATA PACKET RAY 	Starter kit with RAY harness and PHARIO PALM energy absorber. Ideal for those who want to save some money and get comfortable via ferrata equipment.	M0028XX01	XS	850 29.98	65-75 25.5-29.5	45-50 17.5-19.5	X	EN 12277 EN 958:2017 EN 12275 type "K" ⚙️	€1019
		M0028XX02	S	865 30.51	70-80 27.5-31.5	50-55 19.5-21.5			
		M0028XX03	M	885 31.22	75-85 29.5-33.5	55-60 21.5-23.5			
		M0028XX04	L	900 31.75	80-90 31.5-35.5	60-65 23.5-25.5			
		M0028XX05	XL	910 32.10	85-95 33.5-37.5	65-70 25.5-27.5			
FERRATA PACKET II 	Perfect basic package for via ferratas containing TOP harness, PENTA helmet and PHARIO PALM energy absorber.	M0017XX00	UNI	1310 46.21	60-120 24-47	42-66 17-27	X	EN 12277 EN 12492 EN 958 EN 12275 ⚙️	€1019
FERRATA PACKET EXP II 	Complete set for via ferrata with TOP RENTAL harness, ALADIN chest harness with TUBULAR WEBBING to connect sit and chest hardness, PHARIO PALM via ferrata fall absorber and HEX helmet	M0031XX01	XS/M	1510 53.26	55-90 21.5-35.5	35-65 14-25.5	75-110 30-43	EN 12492 EN 12277 EN 958:2017 EN 12275 ⚙️	€1019
		M0031XX04	L/XXL	1590 56.08	75-125 29.5-49	40-75 16-29.5	75-110 30-43		





CUMBERS OF
CUMBERS

Martin Jech, Telefono Azzurro 8a, Cinque Torri, Italy •  Jan Zámečník



CLOTHING

T-SHIRTS, HOODIES,
PANTS, SHORTS,
HATS,
SCARFS,
GLOVES



T – SHIRT BACKBONE JUNIOR

CI038B



Comfortable children's t-shirt for everyday wear, school, sports and other activities. It combines comfort, quality and the SINGING ROCK style.

- relaxed fit for boys and girls
- SINGING ROCK logotype on the front and back
- proudly made in Czechia

Color: black

Size: 140, 146, 152

Material: 100 % cotton (170 g/m²)

HOODY JUNIOR

CI039B



Cozy hoody for boys and girls with the SINGING ROCK logo and distinctive arrow on the front.

- large hood and kangaroo pocket
- SINGING ROCK logo on the back and a smaller logo on the sleeve
- large SINGING ROCK arrow on the chest points in the right direction in the vertical world
- proudly made in Czechia

Color: black (hood yellow inside)

Size: 140, 146, 152 (unisex)

Material: 90 % cotton, 10 % soft polyester



T- SHIRTS		CODE	SIZE	COLOR	MATERIAL	BACK LENGTH cm/in	FRONT LENGTH cm/in	CHEST WIDTH cm/in	WAIST WIDTH cm/in	BOTTOM WIDTH cm/in	SLEEVE CIRCUMFERENCE cm/in	SLEEVE LENGTH cm/in	NECK WIDTH cm/in
BACKBONE 	Men's T-shirt with short sleeves and logo type SINGING ROCK.	C1013BB01	XS	black	100 % cotton	67 26,4	66 26	89 35	91 35,8	94 37	30 11,8	30 11,8	23 9,1
		C1013BB02	S			69 27,2	68 26,8	100 39,4	101 39,8	103 40,6	32 12,6	35 13,8	25 9,8
		C1013BB03	M			71 28	70 27,6	107 42,1	107 42,1	110 43,3	34 13,4	35 13,8	25 9,8
		C1013BB04	L			72 28,4	71 28	115 45,3	115 45,3	120 41,7	38 15	38 15	26 10,2
		C1013BB05	XL			75 29,5	74 29,1	125 49,2	125 49,2	128 50,4	39 15,4	38 15	26 10,2
BACKBONE 	Women's T-shirt with short sleeves and logo type SINGING ROCK.	C1014BB01	XS	black	100 % cotton	60 23,6	60 23,6	73 28,7	69 27,2	83 32,7	28 11	23 9,1	24 9,5
		C1014BB02	S			62 24,4	62 24,4	77 30,3	75 29,5	90 35,4	30 11,8	23 9,1	26 10,2
		C1014BB03	M			65 25,6	64 25,2	86 33,9	80 31,5	95 37,4	32 12,6	25 9,8	26 10,2
		C1014BB04	L			69 27,2	68 26,8	90 35,4	86 33,9	100 39,4	32 12,6	25 9,8	28 11
		C1014BB05	XL			69 27,2	68 26,8	96 37,8	91 35,8	105 41,3	33 13	27 10,6	29 11,4
ROCKET 	Comfortable men's T-shirt made of top quality cotton with elastan, ensures the freedom of movement when climbing or wearing it everyday.	C1028VX01	XS	purple	96 % cotton, 4 % elastan (170 g/m ²)	66 26	66 26	93 36,6	89 35	89 35	35 13,8	28 11	22 8,7
		C1028VX02	S			66 26	66 26	95 37,4	93 36,6	93 36,6	35 13,8	28 11	24 9,5
		C1028VX03	M			68 26,8	68 26,8	103 40,6	100 39,4	100 39,4	35 13,8	31 12,2	24 9,5
		C1028VX04	L			70 27,6	70 27,6	108 42,5	105 41,3	106 41,7	35 13,8	32 12,6	26 10,2
		C1028VX05	XL			74 29,1	74 29,1	113 44,5	110 43,3	110 43,3	37 14,6	34 13,4	26 10,2
ROCKET 	Comfortable women's t-shirt made of top quality cotton with elastan, ensures the freedom of movement when climbing or wearing it everyday.	C1029VX01	XS	purple	96 % cotton, 4 % elastan (170 g/m ²)	60 23,6	60 23,6	74 29,1	69 27,2	82 32,3	29 11,4	18 7,1	22 8,7
		C1029VX02	S			60 23,6	60 23,6	78 30,7	73 28,7	88 34,7	30 11,8	19 7,5	26 10,2
		C1029VX03	M			62 24,4	62 24,4	85 33,5	77 30,3	93 36,6	30 11,8	19 7,5	26 10,2
		C1029VX04	L			64 25,2	64 25,2	90 35,4	82 32,3	100 39,4	32 12,6	21 8,3	28 11
		C1029VX05	XL			68 26,8	68 26,8	94 37	85 33,5	105 41,3	32 12,6	24 9,5	28 11
BLUE MOUNTAIN 	Comfortable men's T-shirt designed by climbers for climbers. Made of top quality cotton with elastan, keeps you moving freely at the crag or at the mountains.	C1032MM01	XS	blue	96 % cotton, 4 % elastan (170 g/m ²)	65 25,6	65 25,6	93 36,6	90 35,4	88 34,7	27 10,6	34 13,4	22 8,7
		C1032MM02	S			65 25,6	65 25,6	98 38,6	96 37,8	96 37,8	29 11,4	34 13,4	24 9,5
		C1032MM03	M			68 26,8	67 26,4	104 40,9	102 40,2	102 40,2	32 12,6	37 14,6	24 9,5
		C1032MM04	L			71 28	70 27,6	110 43,3	107 42,1	107 42,1	32 12,6	37 14,6	25 9,8
		C1032MM05	XL			72 28,4	71 28	116 45,7	112 44,1	112 44,1	35 13,8	38 15	25 9,8
BLUE MOUNTAIN 	Comfortable women's T-shirt designed by climbers for climbers. Made of top quality cotton with elastan, keeps you moving freely at the crag or at the mountains.	C1033MM01	XS	blue	96 % cotton, 4 % elastan (170 g/m ²)	58 22,8	58 22,8	73 28,7	67 26,4	80 31,5	29 11,4	18 7,1	22 8,7
		C1033MM02	S			59 23,2	59 23,2	77 30,3	69 27,2	87 34,3	30 11,8	20 7,9	24 9,5
		C1033MM03	M			61 24	61 24	83 32,7	77 30,3	92 36,2	30 11,8	20 7,9	26 10,2
		C1033MM04	L			62 24,4	62 24,4	92 36,2	84 33,1	101 39,8	32 12,6	23 9,1	26 10,2
		C1033MM05	XL			64 25,2	64 25,2	96 37,8	88 34,7	106 41,7	33 13	24 9,5	28 11
ROCKLIFE long sleeve 	Comfortable men's long-sleeved T-shirt for your climbing activities or everyday wear in a COMFORT FIT cut in a very pleasant meliert material.	C1036VX02	S	burgundy red	40 % cotton, 50 % PES, 10 % elastan	68 26,8	67 26,4	96 37,8	94 37	98 38,6	25 9,8	67 26,4	18 7,1
		C1036VX03	M			69 27,2	69 27,2	102 40,2	96 37,8	102 40,2	25 9,8	68 26,8	18,5 17,3
		C1036VX04	L			70 27,6	70 27,6	106 41,7	100 39,4	106 41,7	25 9,8	69 27,2	19 7,5
		C1036VX05	XL			72 28,4	72 28,4	112 44,1	106 41,7	112 44,1	25 9,8	70 27,6	19,5 17,7
ROCKLIFE long sleeve 	Comfortable women's long-sleeved T-shirt for your climbing activities or everyday wear in a COMFORT FIT cut in a very pleasant meliert material.	C1037AX01	XS	blue	40 % cotton, 50 % PES, 10 % elastan	61 24	61 24	86 33,9	78 30,7	86 33,9	19 7,5	60 23,6	20 7,9
		C1037AX02	S			62 24,4	62 24,4	90 35,4	82 32,3	90 35,4	19 7,5	61 24	20 7,9
		C1037AX03	M			63 24,8	63 24,8	94 37	86 33,9	94 37	19 7,5	62 24,4	21 8,3
		C1037AX04	L			64 25,2	64 25,2	98 38,6	90 35,4	98 38,6	20 7,9	63 24,8	21 8,3
		C1037AX05	XL			65 25,6	65 25,6	102 40,2	94 37	102 40,2	20 7,9	63 24,8	21 8,3
ACTIVE long sleeve 	Comfortable functional long-sleeved T-shirt for cooler days when working at heights or sporting activities.	W9805BX02	S	black	front and back: 92 % PAD supplex, 8 % lycra side panels: 92 % PES, 2 % PAD, 6 % lycra	68 26,8	66 26	94 37	74 29,1	86 33,9	19 7,5	70 27,6	20 7,9
		W9805BX03	M			69 27,2	69 27,2	100 39,4	82 32,3	93 36,6	20 7,9	71 28	21 8,3
		W9805BX04	L			69 27,2	69 27,2	111 43,7	90 35,4	100 39,4	22 8,7	73 28,7	22 8,7
		W9805BX05	XL			72 28,4	72 28,4	114 44,9	93 36,6	104 40,9	22 8,7	74 29,1	23 9,1
		W9805BX06	XXL			74 29,1	72 28,4	120 47,2	99 39	110 43,3	23 9,1	75 29,5	23 9,1
COOL 	Men's functional T-shirt made of cool material for working at heights or sports activities even on the hottest summer days.	W9806BX02	S	black	100 % nylon (front NILIT® Breeze® back CoolMax fresh FX)	76 29,9	76 29,9	101 39,8	96 37,8	98 38,6	35 13,8	37 14,6	24 9,5
		W9806BX03	M			78 30,7	78 30,7	106 41,7	101 39,8	103 40,6	36 14,2	38 15	24 9,5
		W9806BX04	L			80 31,5	80 31,5	111 43,7	106 41,7	108 42,5	37 14,6	39 15,4	26 10,2
		W9806BX05	XL			83 32,7	83 32,7	116 45,7	110 43,3	113 44,5	38 15	40 15,8	26 10,2
		W9806BX06	XXL			86 33,9	86 33,9	121 47,6	115 45,3	118 46,5	39 15,4	41 16,1	26 10,2
POLO T-SHIRT 	Men's piqué polo T-shirt that is sure to look great with any outfit.	W9802BY02	S	black	100 % cotton	72 28,4	71 28	100 39,4	97 38,2	99 39	31 12,2	30 11,8	21 8,3
		W9802BY03	M			72 28,4	71 28	106 41,7	100 39,4	104 40,9	31 12,2	32 12,6	23 9,1
		W9802BY04	L			74 29,1	73 28,7	114 44,9	108 42,5	114 44,9	33 13	35 13,8	26 10,2
		W9802BY05	XL			77 30,3	76 29,9	122 48	116 45,7	120 47,2	38 15	37 14,6	26 10,2
MONKEY 	Fun, comfortable climbing T-shirt made of top quality cotton for your youngest climbing stars.	C1030Y116	116	yellow	100 % cotton, (170 g/m ²)	44 17,3	43 16,9	60 23,6	62 24,4	63 24,8	24 9,5	16 6,3	18 7,1
		C1030Y122	122			46 18,1	45 17,7	64 25,2	65 25,6	66 26	24 9,5	18 7,1	18 7,1
		C1030Y128	128			52 20,5	52 20,5	68 26,8	67 26,4	71 28	26 10,2	20 7,9	20 7,9



T- SHIRTS		CODE	SIZE	COLOR	MATERIAL	BACK LENGTH cm in	FRONT LENGTH cm in	CHEST WIDTH cm in	WAIST WIDTH cm in	BOTTOM WIDTH cm in	SLEEVE CIRCUMFERENCE cm in	SLEEVE LENGTH cm in	NECK WIDTH cm in
BACKBONE JUNIOR	T-shirt made of high quality cotton with SINGING ROCK logo.	C1038BI40	140	black	100 % cotton	50 19,7	50 19,7	74 29,1	74 29,1	76 29,9	30 11,8	21 8,3	20 7,9
		C1038BI46	146			51 20,1	52 20,5	77 30,3	77 30,3	79 31,1	32 12,6	23 9,1	20 7,9
		C1038BI52	152			55 21,7	56 22	78 30,7	80 31,5	82 32,3	32 12,6	23 9,1	22 8,7







HOODIES		CODE	SIZE	COLOR	MATERIAL	BACK LENGTH cm in	FRONT LENGTH cm in	CHEST WIDTH cm in	WAIST WIDTH cm in	BOTTOM WIDTH cm in	SLEEVE CIRCUMFERENCE cm in	SLEEVE LENGTH cm in	NECK WIDTH cm in
HOODY	Unisex sweatshirt with a big hood and a kangaroo pocket.	C1018BY01	XS	black/ yellow	90 % cotton, 10% PES	67 26,4	65 25,6	92 36,2	92 36,2	88 34,7	17 6,69	68 26,8	28 11
		C1018BY02	S			67 26,4	65 25,6	98 38,6	94 37	91 35,8	18 7,1	71 28	28 11
		C1018BY03	M			69 27,2	68 26,8	105 41,3	100 39,4	96 37,8	20 7,9	75 29,5	30 11,8
		C1018BY04	L			72 28,4	70 27,6	110 43,3	107 42,1	100 39,4	20 7,9	78 30,7	30 11,8
		C1018BY05	XL			72 28,4	73 28,7	118 46,5	114 44,9	108 42,5	20 7,9	82 32,3	30 11,8
HOODY FULL ZIP	Men's hoodie with zipper, large hood and two pockets.	C1019BY02	S	black/ yellow	90 % cotton, 10% PES	66 26	65 25,6	109 42,9	100 39,4	87 34,3	18 7,1	73 28,7	30 11,8
		C1019BY03	M			70 27,6	69 27,2	117 46,1	107 42,1	95 37,4	18 7,1	76 29,9	30 11,8
		C1019BY04	L			72 28,4	70 27,6	122 48	114 44,9	100 39,4	18 7,1	78 30,7	30 11,8
		C1019BY05	XL			76 29,9	75 29,5	130 51,2	120 47,2	105 41,3	20 7,9	80 31,5	30 11,8
		C1019BY06	XXL			79 31,1	77 30,3	135 53,2	125 49,2	115 45,3	20 7,9	82 32,3	30 11,8
HOODY FULL ZIP	Women's hoodie with zipper, large hood and two pockets.	C1020BY02	S	black/ yellow	90 % cotton, 10% PES	66 26	66 26	98 38,6	83 32,7	86 33,9	18 7,1	74 29,1	24 9,5
		C1020BY03	M			68 26,8	68 26,8	107 42,1	90 35,4	92 36,2	18 7,1	76 29,9	24 9,5
		C1020BY04	L			70 27,6	70 27,6	114 44,9	95 37,4	100 39,4	20 7,9	80 31,5	24 9,5
		C1020BY05	XL			72 28,4	72 28,4	120 47,2	105 41,3	108 42,5	22 8,7	84 33,1	24 9,5
KIDS HOODY	Warm, cozy and comfortable hoody for the youngest climbers.	C1031M116	116	blue/ yellow	90 % cotton, 10 % PES (300 g/m²)	46 18,1	45 17,7	68 20,8	66 26	61 24	17 6,7	48 18,9	22 8,7
		C1031M122	122			48 18,9	47 18,5	72 28,4	70 27,6	66 26	18 7,1	50 19,7	22 8,7
		C1031M128	128			53 20,1	52 20,5	75 29,5	74 29,1	69 27,2	18 7,1	53 20,9	23 9,1
HOODY JUNIOR	Hoodie made of warm and cosy material with large hood and kangaroo pocket.	C1039BI40	140	black/ yellow	90 % cotton, 10 % PES	51 20,1	50 19,7	92 36,2	88 34,7	84 33,1	24 9,5	55 21,7	24 9,5
		C1039BI46	146			53 20,9	51 20,1	95 37,4	93 36,6	88 34,7	26 10,2	57 22,4	24 9,5
		C1039BI52	152			55 21,7	54 21,3	98 38,6	96 37,8	90 35,4	26 10,2	59 23,2	26 10,2

PANTS / SHORTS		CODE	SIZE	COLOR	MATERIAL	WEIGHT g oz	WAIST WIDTH cm in	HIP WIDTH cm in	THIGH WIDTH cm in	KNEE WIDTH cm in	INSEAM cm in	OUTSEAM cm in	LEG OPEN cm in
APOLLO PANTS	Men's pants for movement in the vertical world and for daily wear to work or school.	C1034SS02	S	antracit	96 % cotton, 4 % spandex	420 14,82	86 33,9	101 39,8	50 19,7	45 17,7	82 32,3	105 41,3	37 14,6
		C1034SS03	M			430 15,17	88 34,7	104 40,9	55 21,7	47 18,5	82 32,3	106 41,7	38 15
		C1034SS04	L			440 15,52	89 35	107 42,1	58 22,8	47 18,5	82 32,3	106 41,7	39 15,4
		C1034SS05	XL			455 16,05	95 37,4	112 44,1	60 23,6	47 18,5	82 32,3	107 42,1	40 15,8
		C1034SS06	XXL			475 16,76	102 40,2	117 46,1	60 23,6	50 19,7	82 32,3	108 42,5	40 15,8
APOLLO SHORTS	Men's shorts for movement in the vertical world and for daily wear to work or school.	C1035SS02	S	antracit	96 % cotton, 4 % spandex	265 9,35	85 33,5	101 39,8	59 23,2	x	27 10,6	52 20,5	51 20,1
		C1035SS03	M			275 9,70	89 35	101 39,8	62 24,4	x	27 10,6	53 20,9	51 20,1
		C1035SS04	L			285 10,05	92 36,2	104 40,9	63 24,8	x	27 10,6	53 20,9	51 20,1
		C1035SS05	XL			300 10,58	98 38,6	107 42,1	63 24,8	x	27 10,6	53 20,9	52 20,5
		C1035SS06	XXL			320 11,29	100 39,4	112 44,1	65 25,6	x	27 10,6	53 20,9	52 20,5

BELTS FOR TROUSERS		CODE	SIZE	COLOR	MATERIAL	WIDTH	LENGTH cm in
BELT ROCK&LOCK	SINGING ROCK belt for trousers with the Rock&Lock smart buckle.	C909IXX03	M/L	MIX	harness webbing (PAD), metal buckle	20 mm	110 43
		C909IXX05	XL				130 51
		C9093XX03	M/L				110 43
		C9093XX05	XL				130 51
SPEED BELT	SINGING ROCK belt with SPEED buckle for fast releasing.	C9092XX03	M/L	MIX	harness webbing (PAD), metal buckle	44 mm	110 43
		C9092XX05	XL				130 51
		C9092BX03	M/L	black			110 43
		C9092BX05	XL				130 51

HATS AND SCARFS		CODE	SIZE	COLOR	MATERIAL	WEIGHT g/oz	HEAD CIRCUMFERENCE cm/in
SNAPBACK HAT 	Cool Singing Rock snapback cap with flat bill.	C0074BY00	UNI	black/yellow	98 % cotton, 2 % Spandex, mesh 100 % nylon	100 3.53	50-61 19,7-24
TRUCKER HAT 	Trucker hat for casual wear, work or climbing trips.	C0089SX00	UNI	grey	flap 97 % cotton/ 3 % elasthan, front panel 100 % cotton, net 100 % PES	82 2.89	50-61 19,7-24
BASEBALL HAT 	Classic baseball cap for climbers and workers at height.	C0051HH00	UNI	brown	100 % cotton	75 2.65	52-62 20,5-24,4
		C0051BH00		black			
BASEBALL HAT LIGHT 	Lightweight cap for hot sunny days with SINGING ROCK logo.	C0070SL00	UNI	atracit	100 % PES	58 2.05	50-61 19,7-24
HAT NANUK 	Knitted hat with stylish pom-pom in two colour combinations.	C0069BG00	UNI	blue	wool/ acrylic mix, fleece	90 3.17	54 21,3
		C0069PB00	UNI	purple			
BEANIE LOGOS 	Thin beanie ideal under a helmet.	C0054BX03	S-M	black	PES	32 1.13	49-53 19,3-20,9
		C0054BX05	L-XL	black		36 1.27	54-58 21,3-22,8
BEANIE BLACK ARROW 	Thin beanie ideal under a helmet.	C0055BX03	S-M	black	PES	32 1.13	49-53 19,3-20,9
		C0055BX05	L-XL	black		36 1.27	54-58 21,3-22,8
BEANIE PRO 	Protective beanie for cold and windy conditions.	C0087SB02	S-M	black	100 % PES	21 0.74	49-53 19,3-20,9
		C0087SB04	L-XL	black		26 0.92	54-58 21,3-22,8
BEANIE POLAR 	Warm Polartec® Power Stretch® beanie for sport and work activities.	C0090BB00	UNI	black	100 % PES	36 1.27	58-66 22,8-26
SCARF BLACK ARROW 	Multifunctional scarf 8 in 1 with a wide variety of uses.	C0079BX00	UNI (cca 25 x 46 cm)	black	PES	35 1.23	48 18,9
SCARF LOGOS 	Multifunctional scarf 8 in 1 with a wide variety of uses.	C0080BX00	UNI (cca 25 x 46 cm)	black	PES	35 1.23	48 18,9
BALACLAVA PRO 	Balaclava for the ultimate protection of the head, face and neck at cold and extreme conditions.	C0088SB02	S-M	black	52 % PAD, 42 % polypropylen, 6 % elasthan	40 1.41	52-55 20,5-21,7
		C0088SB04	L-XL			48 1.69	56-59 22,1-23,2



GLOVES		CODE	SIZE	COLOR	MATERIAL	WEIGHT g/oz	STANDARD
FALCONER FULL 	Lightweight gloves featuring great grip, dexterity and ability.	C0012YB08	8	black / yellow	cow leather, artificial leather, nylon, neoprene	93 3.28	EN 420
		C0012YB09	9			98 3.46	
		C0012YB10	10			100 3.53	
		C0012YB11	11			107 3.77	
FALCONER TACTICAL 	Lightweight gloves with uncovered tops of thumb, forefinger and middle finger making manipulation of metalwork simpler.	C0013YB08	8	black / yellow	cow leather, artificial leather, nylon, neoprene	85 3.00	EN 420
		C0013YB09	9			90 3.17	
		C0013YB10	10			95 3.35	
		C0013YB11	11			102 3.60	
FALCONER 3/4 	Lightweight gloves with removed tops of fingers making manipulation of metalwork simpler.	C0014YB08	8	black / yellow	cow leather, artificial leather, nylon, neoprene	71 2.50	EN 420
		C0014YB09	9			75 2.65	
		C0014YB10	10			85 3.00	
		C0014YB11	11			94 3.32	
GRIPPY 	Full finger leather gloves suitable for all work or rescue activities	C0006BH08	8	black + beige	leather	100 3.53	EN 420 EN 388
		C0006BH09	9			110 3.88	
		C0006BH10	10			130 4.59	
		C0006BH11	11			140 4.94	
GRIPPY 3/4 	Leather gloves with removed tops of fingers for via ferrata and bigwall climbing.	C0006HH08	8	light and dark beige	leather	75 2.65	EN 420 EN 388
		C0006HH09	9			85 3.00	
		C0006HH10	10			90 3.17	
		C0006HH11	11			95 3.35	
CRAGGY 	Crack climbing gloves providing very effective hand protection against scratching.	C0082YB02	S	yellow / black	artificial leather, rubber, polyester	45 1.59	X
		C0082YB03	M			55 1.94	
		C0082YB04	L			70 2.47	
		C0082YB05	XL			85 3.00	
ANKLE PROTECTOR 	Protection against scratching the ankle while climbing in low climbing shoes.	C0083YB00	UNI	yellow / black	artificial leather, rubber, polyester	38 1.34	X





-
-
-
-
-
-
-
-
-
-
-
-
-
-





ACCESSORIES

SLACKLINE, CRASH PADS,
CHALK BAGS, CHALK,
BAGS



CHALK BAG DUO

C3006



Chalk bag with a minimalistic design

- simple design with the SINGING ROCK logotype
- proven design ensures optimal use of chalk
- prompt dust proof closing system and a braced welt provide easy handling of the chalk bag
- inner material fleece
- equipped with a practical brush holder loop
- loops for the belt or accessory cord attachment
- various colors matching with the current sit harness collection

Colour: blue/gold, green/brown, black/blue, black/green

Weight: 65 g • 2.3 oz

Material: polyester/polyamide, fleece

C3006MZ00	blue/gold
C3006GH00	green/brown
C3006BA00	black/blue
C3006BG00	black/green

CHALK BAG XLARGE

C3005BX00



Large chalk bag with ergonomic shape and enough volume for chalking of the whole hand.

- soft and pleasant fleece lining inside
- dustproof closing system
- wide elastic brush holder for easy brush placement
- double loops for stable attachment to the waist belt

Colour: black

Weight: 70 g • 2.47 oz

Material: PES, fleece

SLACKLINE		CODE	COLOR	WEIGHT g/oz	WIDTH mm	STRENGTH kN	MATERIAL
SLACKLINE 15 m 	Ideal slackline set for the beginners and allrounders, also suitable for the schools, climbing gyms or special training purposes.	C0064BY15	black & yellow	2394 84.45	25	30	low stretch PES
SLACKLINE 25 m 	Slackline set for advanced slackliners with 25 mm strap width and 25 m length.	C0064BY25	black & yellow	2898 102.22	25	30	low stretch PES

CRASH PADS		CODE	COLOR	WEIGHT kg/lb	DIMENSION cm in	PACKED DIMENSIONS cm in	THICKNESS cm in	MATERIAL
FONT 	Lightweight one-part sit start pad.	C0075BX00	yellow/black	1,2 2.65	90×50 35.4×19.7	90×50 35.4×19.7	5 2	25% PE foam, 75% polyurethane foam, nylon + antislip finishing
MAGIC 	Two-part crash pad with two-layer shock absorbing construction	C0076BX00	yellow/black	5,1 11.30	116×95×10 45.7×37.4×3.9	58×95×20 22.8×37.4×7.9	10 3.9	25% PE foam, 75% polyurethane foam, nylon + antislip finishing
HUECO 	Three-part crash pad with two-layer shock absorbing construction.	C0077BX00	yellow/black	6,7 14.77	150×100 59×39.4	50×100×30 19.7×39.4×11.8	10 3.9	25% PE foam, 75% polyurethane foam, nylon + antislip finishing

CHALK BAGS		CODE	COLOR	WEIGHT g/oz	MATERIAL
BOULDER BAG 	Chalk bag with a dimension of 4 litres enables spread both hands at the same time with a sufficient layer of climbing chalk.	C3066BY00	yellow/black	205 7.23	PES/PAD
LARGE 	Large chalk bag with SINGING ROCK logotype.	C0002BBX4	black	75 2.65	PES/PAD, fleece
DUO 	Chalk bag with a minimalistic SINGING ROCK design.	C3006ZH00	brown/gold	65 2.29	PES/PAD, fleece
		C3006GH00	brown/green		
		C3006BA00	black/blue		
		C3006BG00	black/green		
XLARGE 	Large chalk bag with ergonomic shape and enough volume for chalking of the whole hand.	C3005BX00	black	70 2.47	PES, fleece
BELT FOR CHALK BAG 	Adjustable magnesium chalk belt with quick release buckle.	C3090XX	black	16 0.56	PAD

CLIMBING CHALK		CODE	WEIGHT g/oz	VOLUME
MAGNUM ball 	Climbing chalk in a textile disposable bag.	M3001WO35	35 1.23	×
MAGNUM ball refill 	Climbing chalk in a practical textile reclosable bag.	M3001WO35R	35 1.23	×

CLIMBING CHALK		CODE	WEIGHT gloz	VOLUME
MAGNUM ball twins 	Climbing chalk in two textile disposable bags.	M3001X070T	2x35 2x1.2	✘
MAGNUM cube 	Climbing chalk pressed into a solid cube.	M3001X056	56 1.98	✘
MAGNUM CRUNCH dose 	Climbing chalk in a practical plastic screw dose.	M3001W10C	100 3.53	✘
MAGNUM CRUNCH bag 	Crushed climbing chalk in a paper bag.	M3001X30P	300 10.58	✘
MAGNUM LIQUID bag 	Liquid magnesium in a disposable bag, serves as a back-up pack or as a test dose.	M3002W010	✘	10 ml
MAGNUM LIQUID tube 	Quick-drying liquid chalk in a practical screw tube.	M3002W150	✘	150 ml

BACKPACKS / GEAR BAGS		CODE	COLOR	WEIGHT gloz	VOLUME l	MAX. LOAD kg	MATERIAL
MOVEMENT BAG 	Resistant traveling bag with wheels for your climbing adventures, business trips or work at height missions.	C0073BY00	black	4600 62.26	110	23	PVC
TARP DUFFLE 	High-capacity transport bag for climbing or working gear.	C0046BB70	black	1820 64.20	70	20	PVC
		C0046BB90		2270 80.07	90	23	
		C0046B120		2650 93.48	120	23	
DRY DUFFLE 	Water resistant dry duffel that opens fully across its length so you can get to your compartment without having to unload half your stuff.	S9003YY40	yellow	780 27.51	40	20	PVC, PE
		S9003YB60	yellow/black	1040 36.68	60	25	
ROCKING 40 	Crag climbing backpack with top and back panel easy access to the main compartment and lots of cool features.	C0086BX40	black	1190 41.98	40	✘	PES, PAD, plastic
ROCKSTAR 28 	Urban style shoulder bag with a removable rope tarp for gym climbing or bouldering.	C0085BX28	black	845 29.81	28	✘	PES, PAD, light alloy
CANYON BAG 	Durable backpack intended mainly for aquatic caves and canyoning. It provides great carrying comfort and water drainage.	S9002YX30	yellow/black	1345 47.44	30	✘	PVC, PES
DRY BAG 	Dry bag with detachable shoulder straps intended for complete waterproof protection of your gear.	S9001YX40	yellow	600 21.16	40	✘	PVC, PE
		S9001BX60	black	800 28.22	60		

BACKPACKS / GEAR BAGS		CODE	COLOR	WEIGHT g/oz	VOLUME l	MAX. LOAD kg	MATERIAL
GEAR BAG 	The transport bag for your gear.	S9000BB35	black	700 24.69	35	x	PVC
		S9000BB50	black	800 28.22	50		
		S9000YY35	yellow	700 24.69	35		
		S9000YY50	yellow	800 28.22	50		
		S9000RR35	red	700 24.69	35		
		S9000RR50	red	800 28.22	50		
CARRY BAG 	Practical bag intended for storage and transport of ropes as well as other gear.	C000YY00	black	940 33.16	28 + 10	28	PVC
ROPE BAG 	Backpack for 50-70 metr rope with 137x137 cm detachable tarp.	C000IBBXX	black	620 21.87	x	x	PAD, PES
ROPE TARP 	You can throw it on the ground in a sand, mud or dirt and the rope stays clean, 120x140 cm.	C0093BX00	black	190 6.70	x	x	PES
MONTY BAG 	Transport bag for your tools or for your stuff to the office.	W1023RR00	red	390 13.76	6.5	10	durable fabric POLYMAR
		W1023SS00	grey				
		W1023YY00	yellow				
BANNER BAG 	Bag made from old Singing Rock banners and handles made from leftover ropes.	P0054XX00	mix	275 9.70	3.5	x	used advertising banners, leftover ropes

OTHER ACCESSORIES		CODE	COLOR	WEIGHT g/oz	SIZE	LENGTH	MATERIAL
SUPER TAPE 	Climbing tape for your fingers.	C0034W125	white	x	12,5 mm	10 m	x
		C0034Y380	yellow		38 mm		
CULTER 	Reliable knife for daily work or emergency situations including belt cutter and window breaker.	A0050HH00	red	208 7.34	x	x	stainless steel, G10 material
RESCUE KNIFE 	Rescue knife with serrated blade, blade length 80 mm, which can be opened with one hand.	A0030YS00	yellow	196 6.91	x	x	tools and clip - stainless steel, handle - plastic
WORK KNIFE 	Knife with selected blade length of 80 mm, which can be opened with one hand includes belt clip.	A0031BS00	black	83 2.93	x	x	blade and clip - stainless steel, handle - plastic
FIRST AID BAG 	Lightweight and compact first aid kit (without contents), many ways of fastening with whistle inside.	C0053RW00	red	61 2.15	13x10x5 cm	x	PAD, PES
FIRST AID BAG LARGE 	Large first aid kit with storage pockets of different sizes (without contents) with whistle inside.	C0058RR00	red	189 6.67	22x18x5 cm	x	PAD, PES







PROMOTIONAL

MUGS, HANDY ACCESSORIES,
HOLDS, STICKERS & BADGES,
BANNERS & POSTERS



MUGS		CODE	WEIGHT gloz	VOLUME	SIZE	THICKNESS	MATERIAL
PITCHER 	Classic beer pitcher for everyone who likes climbing and doing other activities on our vertical playground.	P0010X030	×	0,3 litre	×	×	glass
		P0010X050	×	0,5 litre	×	×	
BEER MAT SQUARE 	Wooden beer mats under your favorite glass of beer or cup of tea and coffee.	P0047XX01	50 1,76	×	9 x 9 cm	8 mm	plywood
BEER MAT CIRCULAR 	Wooden beer mats under your favorite glass of beer or cup of tea and coffee.	P0047XX02	50 1,76	×	Ø 10,5 cm	8 mm	
TRAVEL MUG 	Travel thermo mug for your favourite coffee, tea or cold drink when you are travelling, camping or working in the office.	P0048X400	170 5,99	400 ml	height 17 cm	×	stainless steel, bamboo, BPA free plastic

HANDY ACCESSORIES		CODE	WEIGHT gloz	THICKNESS mm	SIZE cm in	COLOR	MATERIAL
KEY HOLDER 	Keychain for all climbers who never want to lose their keys again.	P99100X	×	×	×	mix	×
SINGING ROCK PEN 	Ballpoint pen for everyday writing.	P0022XX00	×	×	×	×	×
GROUND COFFEE OUTDOOR 	Coffee for outdoor enthusiasts and coffee lovers. Enjoy the coffee time before / after your climbing or working day.	P0038GU01	10 0,35 (packet)	×	×	×	×
		P0038GB10	10 0,35 (packet)	×	×	×	×
WHOLE BEAN COFFEE CAN 	Whole bean coffee for outdoor enthusiasts and coffee lovers. Enjoy the coffee time before / after your climbing or working day.	P0038W150	150 5,29	×	×	×	×
USB FLASH DRIVE 	Wooden flash drive to transport and store your personal files.	P0019XX00	×	×	×	×	eco-friendly wood
CONDOM SAFETY FIRST 	Condom in the funny SINGING ROCK package comes in handy for your rest days.	P0023XX00	×	×	UNI	×	×
QUICKDRAW COVER 	Antislipery cover to increase the SINGING ROCK logo visibility. Fits for the quickdraw with the width of the sling 11-16 mm and 16-25 mm	P0016BB00	×	×	×	black + yellow/white	×
		P0016BB25					
NOTEPAD A5 	Singing Rock notebook in A5 format.	P0030XX00	×	×	×	×	paper
WRISTBAND 	Silicone bracelets with embossed Singing Rock inscription. Made of high quality rubber for long life.	P0024XX00	×	×	×	various	×

HANDY ACCESSORIES		CODE	WEIGHT g/oz	THICKNESS mm	SIZE cm/in	COLOR	MATERIAL
PAPER BAG 	Eco-friendly paper bag.	P0033XX00	×	×	35×44×18 13.8×17.3×7.1	×	paper
		P0033XX02	×	×	24×33×12 9.5×13×4.7	×	
SIT HARNESS DISPLAY 	Wooden display to present sit harnesses on the wall in a store.	P0044XX00	525 18.51	8	53×42 20.9×16.5	×	plywood
KID'S SIT HARNESS DISPLAY 	Wooden display to present a kid's harness on the wall in a store.	P0045XX00	370 13.05	8	44×30 17.3×11.8	×	plywood
DISPLAY HOLDER 	Stand for the self standing version of the sit harness display.	P0046XX00	10 3.5	8	22.5×4.5 8.7×1.8	×	plywood

HOLDS		CODE	SIZE	COLOR	MATERIAL
ARROW SLOPER 	SINGING ROCK climbing holds for your climbing and bouldering gyms.	P0018YY04	L	yellow	PES
ARROW MUSCLE 	SINGING ROCK climbing holds for your climbing and bouldering gyms.	P0017YY02	S	yellow	PES
		P0017YY03	M		
		P0017YY04	L		

STICKERS AND BADGES		CODE	SIZE
SINGING ROCK STICKERS 	Stickers for all climbers and hard workers.	P0025XX00	×
TEXTILE BADGES 	SINGING ROCK textile embroidered badges.	P0031XX01	10×4 cm
		P0031XX02	15×6 cm

BANNERS AND POSTERS		CODE	SIZE	DIMENSION cm	COLOR	MATERIAL
BANNERS 	SINGING ROCK banners with the holes to hang up.	P0020BB02	S	60×60	black + yellow /white	lightweight PES
		P0020BB03	M	30×150		
		P0020BB04	L	200×100		
		P0020BB05	XL	150×150		
BEACH FLAG 	SINGING ROCK self standing event flag comes with a footstand and carrier bag.	P0021BB00	table	29×60	black + yellow /white	elastic PES
		P0021BB03	M	60×260		
		P0021BB04	L	80×340		
		P0021BB05	XL	85×450		
POSTERS 	Climbing and bouldering posters with our sponsored athletes.	P0027CX00	×	50×70	×	×

ABS	Acrylonitrile butadiene styrene is a common thermoplastic polymer. The most important mechanical properties of ABS are impact resistance and toughness. ABS is stronger than pure polystyrene.
Acryl	Lightweight, soft, and warm, with a wool-like feel fabrics or yarn. Strong and warm, acrylic fiber is often used for sweaters and tracksuits and as linings for boots and gloves, as well as in furnishing fabrics and carpets. It is manufactured as a filament, then cut into short staple lengths similar to wool hairs, and spun into yarn.
Anodizing	Electrolytic passivation process used to increase the thickness of the natural oxide layer on the surface of metal parts. Anodizing increases resistance to corrosion and wear, and provides better adhesion for paint primers and glues than bare metal does.
Bamboo	Cloth, yarn, and clothing made out of bamboo fibres. Bamboo fabric is exceptionally soft and light. It is also incredibly hydrophilic, absorbing more water than other conventional fibres such as cotton and polyester.
Cold forging	Deformation of metal while it is below its recrystallization point. This process is usually less expensive than hot forging and the end product requires little, if any, finishing work. Residual stress of material may occur as it handles high stress and high die loads
Cordura	Brand name for a collection of fabrics used in a wide array of products including luggage, backpacks, trousers, military wear and performance apparel. Cordura fabrics are known for their durability and resistance to abrasions, tears and scuffs. Cordura fabrics are usually made of nylon.
Cortex	Polyamide elastic woven fabrics. Cortex fabrics are designed to ensure the maximum ergonomomy and comfort.
Dyneema	Registered trademark for a synthetic fabric that is stronger than Kevlar®. Dyneema® is composed of ultra high molecular weight polyethylene. It is resistant to water, most chemicals, UV radiation and bacterial.
ED coating	Electrophoretic deposition coating. A characteristic feature of this process is that colloidal particles suspended in a liquid medium migrate under the influence of an electric field (electrophoresis) and are deposited onto an electrode.
Elastane (Spandex)	Synthetic polyether-polyurea copolymer known for its exceptional elasticity. It is stronger and more durable than natural rubber.
EPS	Expanded polystyrene is a rigid and tough, closed-cell foam. It is made of pre-expanded polystyrene beads. Due to its technical properties such as low weight, rigidity, and formability, EPS can be used in a wide range of different applications.
Fiber glass	Type of fiber-reinforced plastic where the reinforcement fiber is specifically glass fiber. The glass fiber may be randomly arranged, flattened into a sheet (called a chopped strand mat), or woven into a fabric. Fiberglass is unique in its strength and yet it is lightweight. Although it is not as strong and stiff as composites based on carbon fiber, it is less brittle, and its raw materials are much cheaper.
Fleece	Soft napped insulating fabric made from a type of polyester called polyethylene terephthalate (PET) or other synthetic fibers. A lightweight, warm, soft and hydrofobic fabric. Regular polar fleece is not wind-proof and does not absorb moisture. It readily generates static electricity.
G10 fiber	High-pressure fiberglass laminate, a kind of composite material. It is created by stacking multiple layers of glass cloth, soaking in epoxy resin, and compressing the resulting material under heat until the epoxy cures. G10 is favoured for its high strength, low moisture absorption, excellent electrical insulating properties and chemical resistance.
HF welding	Joining of materials by supplying High Frequency energy in the form of an electromagnetic field (27.12 MHz) and pressure to the material surfaces to be joined.
Hot forging	Deformation of metal while it is above the recrystallization point. Hot forging is recommended for the deformation of metal that features a high formability ratio. Hot forging provides a homogenized grain structure
Injection	Manufacturing process for producing parts by injecting material into a mould. Material for the part is fed into a heated barrel, mixed, and forced into a mould cavity, where it cools and hardens to the configuration of the cavity.
Kermantle rope	Rope constructed with its interior core protected by a woven exterior sheath designed to optimize strength, durability, and flexibility. The core fibers provide the tensile strength of the rope, while the sheath protects the core from abrasion during use.
Kevlar	Kevlar is the registered trademark for a para-aramid synthetic fiber. Kevlar has many applications, ranging from bicycle tires and racing sails to body armor, because of its high tensile strength-to-weight ratio; by this measure it is 5 times stronger than steel. It is designed to protect users from cuts, abrasions and heat. Kevlar-based protective gear is often considerably lighter and thinner than equivalent gear made of more traditional materials.
Nylon	Generic designation for a family of synthetic polymers, based on aliphatic or semi-aromatic polyamides. Nylon is a thermoplastic silky material that can be melt-processed into fibers, films or shapes. Nylon is very much suitable for hosiery and the knitted fabrics because of its smoothness, light weight and high strength.
Polyamide (PA, PAD)	Macromolecule with repeating units linked by amide bonds. Synthetic polyamides are commonly used in textiles, automotive applications, carpets and sportswear due to their high durability and strength. Fibres are very tear-proof and abrasion-resistant and absorb little moisture (thus good transport of moisture away from the body) and are stretchy, crease-free, but also prone to pilling. Polyamide has the highest resistance of all textile raw materials (also when wet) and is very stretchy.
Polycarbonate	Group of thermoplastic polymers containing carbonate groups in their chemical structures. Polycarbonates used in engineering are strong, tough materials, and some grades are optically transparent.
Polyester (PES)	Category of polymers that contain the ester functional group in their main chain. Fabrics woven or knitted from polyester thread or yarn are used extensively in apparel and home furnishings. Industrial polyester fibers, yarns and ropes are used in car tire reinforcements, fabrics for conveyor belts, safety belts, coated fabrics and plastic reinforcements with high-energy absorption. Polyester has excellent return conduct thanks to the rippling property and is very light. Polyester also retains its shape and is colourfast, as well as resistant to sweat and UV-rays (lightfast). Polyester has a high melting point and transfers can therefore be printed on this material)
Polyethylene (PE)	Most common plastic, which is usually a mixture of similar polymers of ethylene. Polyethylene is of low strength, hardness and rigidity, but has a high ductility and impact strength as well as low friction. It shows strong creep under persistent force, which can be reduced by addition of short fibers. Its primary use is in packaging (plastic bags, plastic films, geomembranes, containers including bottles, etc.)
POLYMAR	Registered trademark for a polyester coated with polyurethane tarpaulin fabric. It is UV and weatherproof resistant.
Polypropylene (PP)	Thermoplastic polymer used in a wide variety of applications including packaging and labeling, textiles (e.g., ropes, thermal underwear and carpets), stationery, plastic parts and reusable containers of various types, laboratory equipment, loudspeakers, automotive components and polymer banknotes. An addition polymer made from the monomer propylene, it is rugged and unusually resistant to many chemical solvents, bases and acids. Polypropylene is the world's second-most widely produced synthetic plastic, after polyethylene.
Polystyrene	Synthetic aromatic polymer made from the monomer styrene. Polystyrene can be solid or foamed. General-purpose polystyrene is clear, hard, and rather brittle. Polystyrene is one of the most widely used plastics. Uses include protective packaging (such as packing peanuts and CD and DVD cases), containers (such as "clamshells"), lids, bottles, trays, tumblers, and disposable cutlery.
Polyvinyl chloride (PVC)	World's third-most widely produced synthetic plastic polymer, after polyethylene and polypropylene. PVC comes in two basic forms: rigid and flexible. The rigid form of PVC is used in construction for pipe and in profile applications such as doors and windows. It is also used for bottles, other non-food packaging, and cards (such as bank or membership cards). In flexible form, it is used in plumbing, electrical cable insulation, imitation leather, signage, phonograph records, inflatable products, and many applications where it replaces rubber.
Polyurethane (PU)	Polymer composed of organic units joined by carbamate (urethane) links. While most polyurethanes are thermosetting polymers that do not melt when heated, thermoplastic polyurethanes are also available.
Ripstop	Woven fabrics, using a special reinforcing technique that makes them resistant to tearing and ripping. During weaving, (thick) reinforcement threads are interwoven at regular intervals in a crosshatch pattern. Advantages of ripstop are the favourable strength-to-weight ratio and that small tears can not easily spread.
Stainless Steel	Steel alloy with a minimum of 10.5% chromium content by mass. Stainless steel is notable for its corrosion resistance. Stainless steel does not readily corrode, rust or stain with water as ordinary steel does. However, it is not fully stain-proof in low-oxygen, high-salinity, or poor air-circulation environments.
Technora	Registered trademark for an aramid that is useful for a variety of applications that require high strength or chemical resistance. It is closely related to Kevlar (see Kevlar).
Thermolite	Synthetic material made by Invista and used as an insulator. The performance fibers are engineered with a differentiated fiber shape, able to produce battings with sought-after lightweight warmth.
Thermotransfer	Digital printing process in which material is applied to paper (or some other material) by melting a coating of ribbon so that it stays glued to the material on which the print is applied.
Ultrasonic finishing	Sound waves with frequencies higher than the upper audible limit of human hearing is joining the load-bearing core and the protective sheath into a compact unit. It is used to finish kermantle ropes ends.
Velcro	Registered trademark for a hook-and-loop fastener, which consists of two components: typically, two lineal fabric strips (or, alternatively, round "dots" or squares) which are attached (sewn or otherwise adhered) to the opposing surfaces to be fastened.
Zinc plating	Prevents oxidation of the protected metal by forming a barrier and by acting as a sacrificial anode if this barrier is damaged.

The list of selected EN standards for mountaineering equipment and personal protective equipment (PPE) against falls from a height which our products fulfill.



EN 354
PPE against falls from a height.
Connecting equipment max. length 2 m
(incl. connectors).



EN 958
Mountaineering equipment Energy
absorbing systems for use in via ferrata
(klettersteig) climbing



EN 361
PPE against falls from a height.
Full body harnesses.

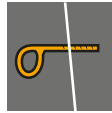

EN 959
Mountaineering equipment
– Rock anchors



EN 362
PPE against falls from a height.
Connectors.



EN 1891
PPE against falls from a height.
Low stretch kernmantel ropes.



EN 388
Protection gloves against mechanical
risks



EN 12275
Mountaineering equipment
– Connectors

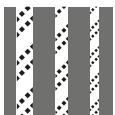

EN 564
Mountaineering equipment
– Accessory cords



EN 12277
Mountaineering equipment
– Harnesses



EN 566
Mountaineering equipment
– Slings



EN 12278
Mountaineering equipment.
Pulleys.



EN 567
Mountaineering equipment.
Rope clamps.



EN 12492
Mountaineering equipment
– Helmets for mountaineers

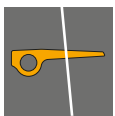

EN 569
Mountaineering equipment - Pitons



EN 12841
PPE against falls from a height.
Descender device for rope access
system and rope adjustment devices.



EN 813
PPE against falls from a height.
Sit harnesses.



EN 13089
Mountaineering equipment - Ice tools



EN 892
Mountaineering equipment.
Dynamic (strech) ropes.



EN 15151
Mountaineering equipment
– Braking devices



EN 893
Mountaineering equipment - Crampons

PRODUCT NAME	PAGE	PRODUCT NAME	PAGE	PRODUCT NAME	PAGE
Accessory cords 4 mm	32	CANYON BAG	98	FALCONER TACTICAL	92
Accessory cords 5 mm	32	CANYON SIT PROTECTION	17	FERRATA PACKET II	85
Accessory cords 6 mm	32	CANYON XP	17	FERRATA PACKET RAY	85
Accessory cords 7 mm	32	CAPTAIN	74	FERRATAPACKET EXP II	85
Accessory cords 8 mm	32	CARRY BAG	99	FIGURE 8 L	65
ACCORD 8.3	24	Center bar II XL	57	FIGURE 8 M	65
ACCORD DRY 8.3	24	Center bar III	57	FIRST AID BAG	99
ACTIVE long sleeve	89	Center bar III FLEX	57	FIRST AID BAG LARGE	99
ADZE	51	COLT	39	FIX	52
ALADIN	17	COLT 16	39	FIX PLUS	52
ALADIN PADDING	17	COLT 16 6PACK	39	FLAT WEBBING	79
ALADIN PLUS	17	COLT 16 MIX	39	FONT	97
ANKLE PROTECTOR	92	COLT 16 MIX 6PACK	39	FOOT LIFT	65
APOLLO PANTS	90	COLT 16 WIRE	39	FOOTER II	80
APOLLO SHORTS	90	COLT 16 WIRE 6PACK	39	FOOTER II COMPLETE	80
ARA	16	COLT 17 CM	39	FOOTER XP	80
ARROW	79	COLT 17 CM 6PACK	39	FRONT POINT LUCIFER II	57
ARROW MUSCLE	103	COLT 6PACK	39	FRONT POINT LUCIFER III	57
ARROW SLOPER	103	COLT bent	37	GARNET	15
ARTWALL	40	COLT MIX	39	GEAR BAG	99
ARTWALL SET	40	COLT screw	37	GEMINI DRY 7.9	24
ATIKA	32	COLT screw 3PACK	37	GLUE IN ANCHOR	73
BACKBONE	89	COLT traight	37	GRIP STICKER	51
BACKBONE	89	COLT WIRE	39	GRIPPY	92
BACKBONEJUNIOR	90	COLT WIRE bent	37	GRIPPY 3/4	92
BALACLAVA PRO	91	COLT WIRE straight	37	GROUND COFFEE OUTDOOR	102
BANDIT	51	COMPLETE	16	GYM 10.1	26
BANNER BAG	99	CONDOM SAFETY FIRST	102	GYM PACKET	17
BANNERS	103	CONNECTOR	40	HAMMER	51
BASEBALL HAT	91	CONTRA 10.5	29	HAMMER CORD 2 mm	32
BASEBALL HAT LIGHT	91	COOL	89	HAMMER CORD 3 mm	32
BEACH FLAG	103	CRAGGY	92	HANGER PLATE STAINLESS STEEL	73
BEANIE BLACK ARROW	91	CRAMPON BAG	57	HANGER PLATE WITH BOLT	73
BEANIE LOGOS	91	CULTER	99	HANGER PLATE WITH BOLT	73
BEANIE POLAR	91	D STEEL	40	HANGER PLATE ZINC COATED	73
BEANIE PRO	91	D STEEL CONNECTOR screw	40	HAT NANUK	91
BEER MAT CIRCULAR	102	DEFENDER	32	HECTOR BC screw	37
BEER MAT SQUARE	102	DIGGER LIGHT	17	HECTOR BC triple lock	37
BELT FOR CHALK BAG	97	DISPLAYHOLDER	103	HECTOR screw	37
BELT ROCK&LOCK	90	DNA DRY 8.9	24	HECTOR triple lock	37
BLUE MOUNTAIN	89	DOME	15	HERO 9.6	25
BLUE MOUNTAIN	89	DOUBLE STOP PLUS	65	HERO DRY 9.6	25
BORA GP screw	37	DRY BAG	98	HEX	47
BORA screw	37	DRY DUFFLE	98	HEX PADDING	47
BORA triple lock	37	DRY PICK	51	HOODY	90
BORA TWL	37	DUO	97	HOODY FULL ZIP	90
BOULDER BAG	97	DURAN 10.4	26	HOODY FULL ZIP	90
BOUNCER FAKIR II	57	DYNEEMA QUICKDRAW SLING 11 MM	79	HOODY JUNIOR	90
BOUNCER FAKIR III	57	DYNEEMA® SLING 11 mm	79	HUECO	97
BOUNCER LUCIFER II	57	DYNEEMA® SLING 8 mm	79	ICE PICK	51
BOUNCER LUCIFER III	57	EDGE	51	ICE SCREW COVER	61
BOXER	51	EDGE PICK	51	ICE SCREWS BAG	61
BUDDY	65	EDGE ROLLER	32	ICON 9.3	25
BUDDY SET	65	FAKIR III Classic	57	ICON DRY 9.3	25
BUNGEE	52	FAKIR III Semi-classic	57	INDY EVO PLUS	65
BUNGEE 360°	52	FAKIR III Tech	57	JACOB	80
BUNGEE SINGLE	52	FALCONER 3/4	92	JACOB DYNEEMA	80
CAM CLEAN	65	FALCONER FULL	92	KATA 9.7	25

PRODUCT NAME	PAGE	PRODUCT NAME	PAGE	PRODUCT NAME	PAGE
KATA DRY 9.7	25	PHARIO PALM	85	SLACKLINE WEBBING	79
KEY HOLDER	102	PICK SPACER	51	SLING 16 mm	79
KID'S SIT HARNESS DISPLAY	103	PITCHER	102	SNAPBACK HAT	91
KIDS HOODY	90	PITON A3	74	SPEED BELT	90
LADY PACKET	17	PITON A5	74	SPELEO 10.5	31
LARGE	97	PITON V	74	SPELEO R44 10.5	31
LIFT	65	PLUS	69	SPIN	61
LOOP CHAIN	80	POLO T-SHIRT	89	SPINEL	15
LUCIFER III Tech	57	PORTER	42	STATIC 10.5	29
MAGIC	97	POSTERS	103	STATIC 11.0	28
MAGNUM ball	97	PULLEY EXTRA	69	STATIC 9.0	30
MAGNUM ball refill	97	PULLEY EXTRA	69	STATIC R44 10.5	27
MAGNUM ball twins	98	PULLEY SMALL	69	STATIC R44 10.5	28
MAGNUM CRUNCH bag	98	QUICKDRAW COVER	102	STATIC R44 11.0	27
MAGNUM CRUNCH dose	98	QUICKDRAW RUBBER FIX 11 mm	40	STATIC R44 NFPA 10.5	31
MAGNUM cube	98	QUICKDRAW RUBBER FIX 16 mm	40	STATIC R44 NFPA 11	30
MAGNUM LIQUID bag	98	QUICKDRAW SLING 16 mm	79	STATIC R44 NFPA 13	30
MAGNUM LIQUID tube	98	QUICKDRAW SLING 16/25 mm	79	STORM 9.8	26
MAILLON BIG D	42	QUICKDRAW SLING BLACK		STORM DRY 9.8	25
MAILLON BIG DELTA	40	QUICKSPIN	61	STRAP FOR CAM CLEAN	65
MAILLON BIG SQUARE	42	RAMA	65	SUPER TAPE	99
MAILLON BIG TWIST	42	RAMA SET	65	TANDEM PULLEY	69
MAILLON MINI OVAL	40	RAPPELING STATION 12 mm	73	TARP DUFFLE	98
MAILLON SMALL DELTA	40	RAY	15	TARZAN ECONOMIC	16
MAILLON SMALL OVAL	40	REDBLOCK	73	TEXTILE BADGES	103
MASS	51	REGULATOR	80	THERMOCUTTER	32
MERLIN	51	RESCUE KNIFE	99	TOE BAIL SEMI-CLASSIC	57
MIKY PULLEY	69	RHINO	51	TOE BAIL SKI	57
MINI D	42	RIGGING PLATE 1/3	73	TOP	16
MINI D screw	42	RIGGING PLATE 3/5	73	TOP CANYON	17
MINI D screw 40PACK	42	ROB	15	TOP PADDED	16
MINI PEAR	42	ROCK HAMMER	74	TOP RENTAL	16
MONKEY	89	ROCKET	15	TRAVEL MUG	102
MONTY BAG	99	ROCKET	89	TRIPLE LOCK	40
MOVEMENT BAG	98	ROCKET	89	TRUCKER HAT	91
NOTEPAD A5	102	ROCKING 40	98	TUBULAR WEBBING	79
ONYX	15	ROCKLIFE long sleeve	89	TWIN PULLEY	69
OVAL STEEL CONNECTOR screw	40	ROCKLIFE long sleeve	89	TWISTER	73
OVAL STEEL CONNECTOR TRIPLE LOCK	40	ROCKSTAR 28	98	ULTIMA	74
OXY BC screw	38	ROPE BAG	99	USB FLASH DRIVE	102
OXY BC triple lock	38	ROPE PROTECTOR	32	VERSA II	15
OXY BC TWL	38	ROPE TARP	99	VIA FERRATA	38
OXY screw	38	ROPE DANCER II	16	VISION	39
OXY triple lock	38	ROPEMARKER	32	VISION 6PACK	39
OXY TWL	38	SAFETY CHAIN	80	VISION bent	38
OZONE screw	38	SCARF BLACK ARROW	91	VISION straight	38
OZONE triple lock	38	SCARF LOGOS	91	VISION STRAIGHT 6PACK	38
OZONE TWL	38	SCORE 10.1	26	WHOLE BEAN COFFEE CAN	102
PACKET RAY	17	SCORE DRY 10.1	26	WIZARD	51
PALM	38	SENTINEL	74	WIZARD LIGHT	51
PAPER BAG	103	SERAC	16	WORK KNIFE	99
PATRON 11.0	26	SHUTTLE	65	WRISTBAND	102
PEARL	15	SINGING ROCK PEN	102	XLARGE	97
PENTA	47	SINGING ROCK STICKERS	103	ZAZA	16
PENTA JUNIOR	47	SIR	65		
PENTA PADDING	47	SIT HARNESS DISPLAY	103		
PHARIO 360°	85	SLACKLINE 15 m	97		
PHARIO LITE	85	SLACKLINE 25 m	97		

PRODUCT CODE	PAGE	PRODUCT CODE	PAGE	PRODUCT CODE	PAGE	PRODUCT CODE	PAGE	PRODUCT CODE	PAGE
A0030YS00	99	C0082YB05	92	C1019BY03	90	C1039BI52	90	C5038OS03	15
A0031BS00	99	C0083YB00	92	C1019BY04	90	C2000X011	79	C5038OS04	15
A0050HH00	99	C0084XX11	40	C1019BY05	90	C2000X013	79	C5038OS05	15
C0001BBXX	99	C0084XX16	40	C1019BY06	90	C2000X016	79	C5038OS06	15
C0001YY00	99	C0085BX28	98	C1020BY02	90	C2000X020	79	C5056BB00	17
C0002BBX4	97	C0086BX40	98	C1020BY03	90	C2000X030	79	C5056BY00	17
C0006BH08	92	C0087SB02	91	C1020BY04	90	C2001X030	79	C5057BY00	17
C0006BH09	92	C0087SB04	91	C1020BY05	90	C2001X060	79	C5058	17
C0006BH10	92	C0088SB02	91	C1028VX01	89	C2001X080	79	C5067BO03	15
C0006BH11	92	C0088SB04	91	C1028VX02	89	C2001X120	79	C5067BO05	15
C0006HH08	92	C0089SX00	91	C1028VX03	89	C2001X150	79	C5069OA00	16
C0006HH09	92	C0090BB00	91	C1028VX04	89	C2001X240	79	C5073RT04	15
C0006HH10	92	C0091FX02	47	C1028VX05	89	C2002B013	79	C5075OX01	15
C0006HH11	92	C0091FX04	47	C1029VX01	89	C2002B016	79	C5075OX02	15
C0012YB08	92	C0091FX05	47	C1029VX02	89	C2002B020	79	C5075OX03	15
C0012YB09	92	C0091GX02	47	C1029VX03	89	C2002B030	79	C5075OX04	15
C0012YB10	92	C0091GX04	47	C1029VX04	89	C2004X060	79	C5075OX05	15
C0012YB11	92	C0091GX05	47	C1029VX05	89	C2004X120	79	C5075OX06	15
C0013YB08	92	C0091JY02	47	C1030Y116	89	C2075X060	79	C5076BX01	15
C0013YB09	92	C0091SX02	47	C1030Y122	89	C2075X080	79	C5076BX02	15
C0013YB10	92	C0091SX04	47	C1030Y128	89	C2075X120	79	C5076BX03	15
C0013YB11	92	C0091SX05	47	C1031M116	90	C2075X150	79	C5076BX04	15
C0014YB08	92	C0091YX02	47	C1031M122	90	C2075X240	79	C5076BX05	15
C0014YB09	92	C0091YX04	47	C1031M128	90	C2085X011	79	C5078RB01	16
C0014YB10	92	C0091YX05	47	C1032MM01	89	C2085X013	79	C5078RB04	16
C0014YB11	92	C0092XX02	47	C1032MM02	89	C2085X016	79	C5078SB01	16
C0034WI25	99	C0092XX03	47	C1032MM03	89	C2085X020	79	C5078SB04	16
C0034Y380	99	C0092XX05	47	C1032MM04	89	C2085X030	79	C5079WB02	16
C0035A000	79	C0093BX00	99	C1032MM05	89	C2087A012	79	C5079WB03	16
C0037BB00	79	C0710BS	16	C1033MM01	89	C2087X012	79	C5079WB04	16
C0037RR00	79	C0900AX03	47	C1033MM02	89	C2087X017	79	C5079WB05	16
C0046BI20	98	C0900AX04	47	C1033MM03	89	C2088WY00	80	C5079WB06	16
C0046BB70	98	C0900MX03	47	C1033MM04	89	C2150BY	80	C5080SS01	15
C0046BB90	98	C0900MX04	47	C1033MM05	89	C2151BY00	80	C5080SS02	15
C0051BH00	91	C0900RX03	47	C1034SS02	90	C2152BR00	80	C5080SS05	15
C0051HH00	91	C0900RX04	47	C1034SS03	90	C2317YB00	85	C5082ZH01	15
C0053RW00	99	C0900WX03	47	C1034SS04	90	C2318YB00	85	C5082ZH02	15
C0054BX03	91	C0900WX04	47	C1034SS05	90	C2319YB00	85	C5082ZH03	15
C0054BX05	91	C0900YX03	47	C1034SS06	90	C2419BI20	80	C5082ZH04	15
C0055BX03	91	C0900YX04	47	C1035SS02	90	C2419BI40	80	C5082ZH05	15
C0055BX05	91	C0901SB03	47	C1035SS03	90	C2419X120	80	C5083LX01	15
C0058RR00	99	C0901SB04	47	C1035SS04	90	C2419X140	80	C5083LX02	15
C0064BY15	97	C1013BB01	89	C1035SS05	90	C3005BX00	97	C5083LX03	15
C0064BY25	97	C1013BB02	89	C1035SS06	90	C3006BA00	97	C5083LX04	15
C0065BY00	79	C1013BB03	89	C1036VX02	89	C3006BG00	97	C5083LX05	15
C0069BG00	91	C1013BB04	89	C1036VX03	89	C3006GH00	97	C5084HX01	15
C0069PB00	91	C1013BB05	89	C1036VX04	89	C3006ZH00	97	C5084HX02	15
C0070SL00	91	C1014BB01	89	C1036VX05	89	C3066BY00	97	C5084HX03	15
C0073BY00	98	C1014BB02	89	C1037AX01	89	C3090XX	97	C5084HX04	15
C0074BY00	91	C1014BB03	89	C1037AX02	89	C5029BS00	17	C5084HX05	15
C0075BX00	97	C1014BB04	89	C1037AX03	89	C5030BS02	17	C5084HX06	15
C0076BX00	97	C1014BB05	89	C1037AX04	89	C5030BS03	17	C5084MX01	15
C0077BX00	97	C1018BY01	90	C1037AX05	89	C5030BS05	17	C5084MX02	15
C0079BX00	91	C1018BY02	90	C1038BI40	90	C5031BB00	16	C5084MX03	15
C0080BX00	91	C1018BY03	90	C1038BI46	90	C5031BS00	16	C5084MX05	15
C0082YB02	92	C1018BY04	90	C1038BI52	90	C5032BS00	16	C5084MX05	15
C0082YB03	92	C1018BY05	90	C1039BI40	90	C5038OS01	15	C5084MX05	15
C0082YB04	92	C1019BY02	90	C1039BI46	90	C5038OS02	15	C5084MX05	15

PRODUCT CODE	PAGE	PRODUCT CODE	PAGE	PRODUCT CODE	PAGE	PRODUCT CODE	PAGE	PRODUCT CODE	PAGE
C5084MX06	15	K0122BB07	38	L0031XX00	32	L0231RR10	29	L0360GG04	26
C5086LX01	16	K0122EE05	38	L0041AG10	32	L0231RR20	29	L0360GG05	26
C5086LX02	16	K0122EE06	38	L0051BB10	32	L0231WR10	29	L0360GG06	26
C9091XX03	90	K0122EE07	38	L0051OG10	32	L0231WR20	29	L0360GG07	26
C9091XX05	90	K0123BC05	38	L0061BB10	32	L0240WR03	31	L0360GG08	26
C9092BX03	90	K0123BC06	38	L0061YG10	32	L0240WR04	31	L0360GG10	26
C9092BX05	90	K0123BC07	38	L0071RG10	32	L0240WR05	31	L0361GG20	26
C9092XX03	90	K0123EC05	38	L0081PG10	32	L0240WR06	31	L0364LA03	26
C9092XX05	90	K0123EC06	38	L0220BB03	30	L0240WR07	31	L0364LA04	26
C9093XX03	90	K0123EC07	38	L0220BB04	30	L0240WR08	31	L0364LA05	26
C9093XX05	90	K0124ST09	38	L0220BB05	30	L0240WR10	31	L0364LA06	26
C9630BB00	17	K0124SY09	38	L0220BB06	30	L0241WR10	31	L0364LA07	26
K0006RP00	73	K031DSD00	65	L0220BB07	30	L0241WR20	31	L0364LA08	26
K0009EE00	38	K032SIR00	65	L0220BB08	30	L0250BB03	28	L0364LA10	26
K0009EE60	38	K4080ZO	40	L0220BB10	30	L0250BB04	28	L0365LA20	26
K0016AA00	38	K4081ZO	40	L0220WR03	30	L0250BB05	28	L0380YX03	25
K0016BB00	38	K4241ZO05	40	L0220WR04	30	L0250BB06	28	L0380YX04	25
K0017AA00	38	K4241ZO07	40	L0220WR05	30	L0250BB07	28	L0380YX05	25
K0017BB00	38	K4310PP00	40	L0220WR06	30	L0250BB08	28	L0380YX06	25
K0018AA00	38	K5052EE00	42	L0220WR07	30	L0250BB10	28	L0380YX07	25
K0018BB00	38	K5182EE00	42	L0220WR08	30	L0250RR03	28	L0380YX08	25
K0025EE00	38	K5330PE	38	L0220WR10	30	L0250RR04	28	L0380YX10	25
K0027BY00	42	K6021BB	65	L0221BB10	30	L0250RR05	28	L0381YX20	25
K0027BY40	42	K6021EE	65	L0221BB20	30	L0250RR06	28	L0384RX03	25
K0027YX00	42	K6031BB	65	L0221WR10	30	L0250RR07	28	L0384RX04	25
K0030OG00	73	K6031EE	65	L0221WR20	30	L0250RR08	28	L0384RX05	25
K0043OX00	65	K6132BB	65	L0230BB03	29	L0250RR10	28	L0384RX06	25
K0043SX00	65	K6132EE	65	L0230BB04	29	L0250WR03	28	L0384RX07	25
K0050OS01	32	K6140BB00	65	L0230BB05	29	L0250WR04	28	L0384RX08	25
K0050OS03	32	K6140EE00	65	L0230BB06	29	L0250WR05	28	L0384RX10	25
K0101BX00	65	K6604E011	39	L0230BB07	29	L0250WR06	28	L0385RX20	25
K0107BB00	37	K6604E611	39	L0230BB08	29	L0250WR07	28	L0430BB03	27
K0107BP00	37	K6613E011	39	L0230BB10	29	L0250WR08	28	L0430BB04	27
K0107EE00	37	K6715E011	39	L0230KK03	29	L0250WR10	28	L0430BB05	27
K0107EP00	37	K6715E017	39	L0230KK04	29	L0251BB10	28	L0430BB06	27
K0108BB00	37	K6715E611	39	L0230KK05	29	L0251BB20	28	L0430BB07	27
K0108EE00	37	K6715E617	39	L0230KK06	29	L0251RR10	28	L0430BB08	27
K0110BB00	37	K6716E011	39	L0230KK07	29	L0251RR20	28	L0430BB10	27
K0110EE00	37	K6719E016	39	L0230KK08	29	L0251WR10	28	L0430KK03	27
K0111BB00	37	K6719E616	39	L0230KK10	29	L0251WR20	28	L0430KK04	27
K0111EE00	37	K6720E016	39	L0230RR03	29	L0260WX03	29	L0430KK05	27
K0112BB00	37	K6720E616	39	L0230RR04	29	L0260WX04	29	L0430KK06	27
K0112EE00	37	K6721E016	39	L0230RR05	29	L0260WX05	29	L0430KK07	27
K0112XX30	37	K6721E616	39	L0230RR06	29	L0260WX06	29	L0430KK08	27
K0113EE00	37	K695013	40	L0230RR07	29	L0260WX07	29	L0430KK10	27
K0114BB00	37	K695016	40	L0230RR08	29	L0260WX08	29	L0430RR03	28
K0114BC00	37	K695020	40	L0230RR10	29	L0260WX10	29	L0430RR04	28
K0114EC00	37	K695030	40	L0230WR03	29	L0261WX10	29	L0430RR05	28
K0114EE00	37	K695060	40	L0230WR04	29	L0261WX20	29	L0430RR06	28
K0119BB00	37	K82006Z	40	L0230WR05	29	L0340AX03	26	L0430RR07	28
K0119EE00	37	K82008Z	40	L0230WR06	29	L0340AX04	26	L0430RR08	28
K0120EE00	37	K82207Z	40	L0230WR07	29	L0340AX05	26	L0430RR10	28
K0121BB00	37	K82210Z	40	L0230WR08	29	L0340AX06	26	L0430WR03	28
K0121BC00	37	K82310Z	42	L0230WR10	29	L0340AX07	26	L0430WR04	28
K0121EC00	37	K82410Z	42	L0231BB10	29	L0340AX08	26	L0430WR05	28
K0121EE00	37	K82508Z	42	L0231BB20	29	L0340AX10	26	L0430WR06	28
K0122BB05	38	K9000BB03	42	L0231KK10	29	L0341AX20	26	L0430WR07	28
K0122BB06	38	L0021XX00	32	L0231KK20	29	L0360GG03	26	L0430WR08	28

PRODUCT CODE	PAGE	PRODUCT CODE	PAGE	PRODUCT CODE	PAGE	PRODUCT CODE	PAGE	PRODUCT CODE	PAGE
L0430WR10	28	L0510AG07	24	L0541BB20	26	L3060CX03	24	P0024XX00	102
L0431BB10	27	L0510AG08	24	L0541YX20	26	L3060CX04	24	P0025XX00	103
L0431BB20	27	L0510AG10	24	L0570AA03	25	L3060CX05	24	P0027CX00	103
L0431KK10	27	L0510GA03	24	L0570AA04	25	L3060CX06	24	P0030XX00	102
L0431KK20	27	L0510GA04	24	L0570AA05	25	L3060CX07	24	P0031XX01	103
L0431RR10	28	L0510GA05	24	L0570AA06	25	L3060CX08	24	P0031XX02	103
L0431RR20	28	L0510GA06	24	L0570AA07	25	L3060CX10	24	P0033XX00	103
L0431WR10	28	L0510GA07	24	L0570AA08	25	L3061CX20	24	P0033XX02	103
L0431WR20	28	L0510GA08	24	L0570AA10	25	M0014XX01	17	P0038GB10	102
L0440WR03	31	L0510GA10	24	L0571AA20	25	M0014XX02	17	P0038GU01	102
L0440WR04	31	L0511AG20	24	L0580AA03	25	M0014XX03	17	P0038W150	102
L0440WR05	31	L0511GA20	24	L0580AA04	25	M0014XX04	17	P0044XX00	103
L0440WR06	31	L0514GO03	24	L0580AA05	25	M0014XX05	17	P0045XX00	103
L0440WR07	31	L0514GO04	24	L0580AA06	25	M0017XX00	85	P0046XX00	103
L0440WR08	31	L0514GO05	24	L0580AA07	25	M0027XX03	17	P0047XX01	102
L0440WR10	31	L0514GO06	24	L0580AA08	25	M0027XX05	17	P0047XX02	102
L0441WR10	31	L0514GO07	24	L0580AA10	25	M0028XX01	85	P0048X400	102
L0441WR20	31	L0514GO08	24	L0581AA20	25	M0028XX02	85	P0054XX00	99
L0450BB03	27	L0514GO10	24	L3020RX03	24	M0028XX03	85	P99100X	102
L0450BB04	27	L0514OG03	24	L3020RX04	24	M0028XX04	85	R0430BB04	31
L0450BB05	27	L0514OG04	24	L3020RX05	24	M0028XX05	85	R0430BB06	31
L0450BB06	27	L0514OG05	24	L3020RX06	24	M0029XX01	17	R0430BB09	31
L0450BB07	27	L0514OG06	24	L3020RX07	24	M0029XX02	17	R0430KK04	31
L0450BB08	27	L0514OG07	24	L3020RX08	24	M0029XX03	17	R0430KK06	31
L0450BB10	27	L0514OG08	24	L3020RX10	24	M0029XX04	17	R0430KK09	31
L0450OO03	27	L0514OG10	24	L3020YX03	24	M0029XX05	17	R0430RR04	31
L0450OO04	27	L0515GO20	24	L3020YX04	24	M0029XX06	17	R0430RR06	31
L0450OO05	27	L0515OG20	24	L3020YX05	24	M0031XX01	85	R0430RR09	31
L0450OO06	27	L0520GA03	25	L3020YX06	24	M0031XX04	85	R0430WR04	31
L0450OO07	27	L0520GA04	25	L3020YX07	24	M0200XX00	65	R0430WR06	31
L0450OO08	27	L0520GA05	25	L3020YX08	24	M0201XX00	65	R0430WR09	31
L0450OO10	27	L0520GA06	25	L3020YX10	24	M3001W10C	98	R0431BB10	31
L0450RR03	27	L0520GA07	25	L3021YX20	24	M3001WO35	97	R0431BB18	31
L0450RR04	27	L0520GA08	25	L3040GA03	26	M3001WO35R	97	R0431BB20	31
L0450RR05	27	L0520GA10	25	L3040GA04	26	M3001X056	98	R0431KK10	31
L0450RR06	27	L0521GA20	25	L3040GA05	26	M3001X30P	98	R0431KK18	31
L0450RR07	27	L0524GW03	25	L3040GA06	26	M3001XO70T	98	R0431KK20	31
L0450RR08	27	L0524GW04	25	L3040GA07	26	M3002W010	98	R0431RR10	31
L0450RR10	27	L0524GW05	25	L3040GA08	26	M3002W150	98	R0431RR18	31
L0450WG03	27	L0524GW06	25	L3040GA10	26	P0010X030	102	R0431RR20	31
L0450WG04	27	L0524GW07	25	L3041GA20	26	P0010X050	102	R0431WR10	31
L0450WG05	27	L0524GW08	25	L3044AG03	25	P0016BB00	102	R0431WR18	31
L0450WG06	27	L0524GW10	25	L3044AG04	25	P0016BB25	102	R0431WR20	31
L0450WG07	27	L0525GW20	25	L3044AG05	25	P0017YY02	103	R0450BB04	30
L0450WG08	27	L0540BB03	26	L3044AG06	25	P0017YY03	103	R0450BB06	30
L0450WG10	27	L0540BB04	26	L3044AG07	25	P0017YY04	103	R0450BB09	30
L0451BB10	27	L0540BB05	26	L3044AG08	25	P0018YY04	103	R0450OO04	30
L0451BB20	27	L0540BB06	26	L3044AG10	25	P0019XX00	102	R0450OO06	30
L0451OO10	27	L0540BB07	26	L3045AG10	25	P0020BB02	103	R0450OO09	30
L0451OO20	27	L0540BB08	26	L3050RY03	26	P0020BB03	103	R0450RR04	30
L0451RR10	27	L0540BB10	26	L3050RY04	26	P0020BB04	103	R0450RR06	30
L0451RR20	27	L0540YX03	26	L3050RY05	26	P0020BB05	103	R0450RR09	30
L0451WG10	27	L0540YX04	26	L3050RY06	26	P0021BB00	103	R0450WG04	30
L0451WG20	27	L0540YX05	26	L3050RY07	26	P0021BB03	103	R0450WG06	30
L0510AG03	24	L0540YX06	26	L3050RY08	26	P0021BB04	103	R0450WG09	30
L0510AG04	24	L0540YX07	26	L3050RY10	26	P0021BB05	103	R0451BB010	30
L0510AG05	24	L0540YX08	26	L3051RY20	26	P0022XX00	102	R0451BB018	30
L0510AG06	24	L0540YX10	26			P0023XX00	102	R0451BB020	30

PRODUCT CODE	PAGE	PRODUCT CODE	PAGE	PRODUCT CODE	PAGE	PRODUCT CODE	PAGE	PRODUCT CODE	PAGE
R0451OO010.....	30	RK110BB000.....	51	RK610XX03.....	57	RK800EE00.....	69	W0087BY05.....	16
R0451OO018.....	30	RK111BY000.....	52	RK610XX05.....	57	RK801BB00.....	69	W1023RR00.....	99
R0451OO020.....	30	RK111BY001.....	52	RK611XX02.....	57	RK801EE00.....	69	W1023SS00.....	99
R0451RR10.....	30	RK112WX000.....	52	RK611XX03.....	57	RK802BB00.....	69	W1023YY00.....	99
R0451RR18.....	30	RK113BB000.....	51	RK611XX05.....	57	RK802EE00.....	69	W1024BX00.....	80
R0451RR20.....	30	RK114BB000.....	51	RK612XX000.....	57	RK803BB00.....	69	W1025BX00.....	80
R0451WG10.....	30	RK115XX000.....	51	RK613XX000.....	57	RK804BX0L.....	65	W1027B080.....	32
R0451WG18.....	30	RK116XX000.....	51	RK702XX10.....	73	RK804BX0R.....	65	W1027B120.....	32
R0451WG20.....	30	RK117WX000.....	52	RK702XX12.....	73	RK805BX00.....	65	W1051BX00.....	80
R0460WB04.....	30	RK118WX000.....	52	RK703XX10.....	73	RK806BB00.....	69	W8100B050.....	32
R0460WB06.....	30	RK206AX00C.....	57	RK704XX10.....	73	RK807BX0L.....	65	W8100B070.....	32
R0460WB09.....	30	RK206AX00S.....	57	RK704XX12.....	73	RK807BX0P.....	65	W8100B100.....	32
R0461WB10.....	30	RK206AX00T.....	57	RK705XX00.....	74	RK808BB00.....	69	W8100B120.....	32
R0461WB18.....	30	RK207AX00T.....	57	RK706XX00.....	74	RK808OS00.....	69	W9802BY02.....	89
R0461WB20.....	30	RK251XX000.....	57	RK708XX03.....	74	RK900PP00.....	32	W9802BY03.....	89
RK003YX00H.....	51	RK302SX012.....	61	RK708XX05.....	74	S0101YB00.....	17	W9802BY04.....	89
RK004YX00A.....	51	RK302SX017.....	61	RK708XX07.....	74	S9000BB35.....	99	W9802BY05.....	89
RK005TX055.....	51	RK302SX022.....	61	RK709XX05.....	74	S9000BB50.....	99	W9805BX02.....	89
RK005TX062.....	51	RK303SX012.....	61	RK709XX07.....	74	S9000RR35.....	99	W9805BX03.....	89
RK005TX069.....	51	RK303SX017.....	61	RK709XX09.....	74	S9000RR50.....	99	W9805BX04.....	89
RK006WX052.....	51	RK303SX022.....	61	RK710XX08.....	74	S9000YY35.....	99	W9805BX05.....	89
RK006WX059.....	51	RK351XX000.....	61	RK710XX10.....	74	S9000YY50.....	99	W9805BX06.....	89
RK007BX058.....	51	RK352XX000.....	61	RK710XX12.....	74	S9001BX60.....	98	W9806BX02.....	89
RK007BX065.....	51	RK500XX00.....	73	RK711XX00.....	74	S9001YX40.....	98	W9806BX03.....	89
RK007BX072.....	51	RK601YY000.....	57	RK713BB00.....	73	S9002YX30.....	98	W9806BX04.....	89
RK008AX00A.....	51	RK602YY000.....	57	RK714BB00.....	73	S9003YB60.....	98	W9806BX05.....	89
RK009AX00H.....	51	RK605BB000.....	57	RK715XX10.....	73	S9003YY40.....	98	W9806BX06.....	89
RK105BB000.....	51	RK606BB005.....	57	RK715XX12.....	73	W0059BR00.....	16	X0004GB00.....	32
RK106BB000.....	51	RK607AX000.....	57	RK716XX10.....	73	W0059BR01.....	16	X0015XX00.....	32
RK107BB000.....	51	RK608AX000.....	57	RK716XX12.....	73	W0085BB00.....	65		
RK108BB000.....	51	RK609YY000.....	57	RK750XX00.....	74	W0087BY01.....	16		
RK109BB000.....	51	RK610XX02.....	57	RK800BB00.....	69	W0087BY03.....	16		





Rock&Lock

Patented smart buckle used on SINGING ROCK harnesses and other products enables to lock and open very quickly.



Lady fit

Specially designed products for women.



Route 44

SINGING ROCK patented technology for rope production. A rope is produced on 44 carrier machine which provides great handling, low weight and durability.



Inter Core

The unique patented technology providing maximum safety even in case of a damaged sheath. The rope is made from 4 layers of parallel core filaments, braided core, braided intermediate sheath made from staple fibres and single tech sheath.



Single Tech

With the Single Tech system each strand is braided into the sheath separately. Single Tech sheath construction increases the rope's wear resistance and improves the rope's mechanical properties, such as flexibility.



Single rope

Marking of single dynamic rope for climbing and mountaineering used in single strand.



Half rope

Marking of half rope for mountaineering, multipitch and ice climbing. Individual strands of rope are used in alternation in the protection system. This system reduces the risk of rope breakage caused by falling stones, and provides maximum safety in alpine conditions and for difficult climbs.



Twin rope

Marking of twin ropes for mountaineering, multipitch and ice climbing. Pairs of the same type of rope are always used, sharing the same protection points. Twin ropes guarantee a high level of safety, especially for multipitch climbing in alpine conditions.

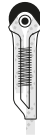

Stitched eye

sewn loop at the end of kernmantle low stretch rope used as a substitute of a knot. Used mainly to attach ropes to anchor or attachment points.



UIAA

Products marked with this symbol meet strict UIAA safety requirements. The UIAA is the International Mountaineering and Climbing Federation. In most cases, UIAA requirements are sometimes stricter than EN standards.



UIAA Water repellent

A standard for water repellent ropes approved by the UIAA Safety Commission. To pass the test at a certified laboratory, the amount of absorbed water must not be greater than 5% of the rope's weight. For comparison, a non-treated rope absorbs around 50% of water in this test, and ropes labelled as „dry“ but lacking adequate treatments can absorb between 20% and 40% of water.



Symbol of compliance

The CE symbol declares that the product is in compliance with the safety requirements of the applicable European standard. The number after the symbol CE (e.g. CE 1019) identifies the relevant accredited testing lab.



ANSI

American National Standards Institute – is a private non-profit organization that oversees the development of voluntary consensus standards for products, services, processes, systems, and personnel in the United States.[3] The organization also coordinates U. S. standards with international standards so that American products can be used worldwide.



NFPA

The National Fire Protection Association is a US nonprofit organization devoted to eliminating death, injury, property and economic loss due to fire, electrical and related hazards. It is widely known as an organization that creates and maintains standards and codes for usage and adoption by local governments.

THAT'S SINGING ROCK

Our company is located in the Czech Republic, in the heart of Europe. Our headquarter is near Krkonoše National Park and Bohemian Paradise where the amazing and unique sandstone rock climbing areas are situated. Most of our staff are climbers or workers at height, alpinists or backcountry skiers. All of us love the vertical playground. The great group of people who create the true SINGING ROCK culture is the priceless benefit for most of us who work at the company. We develop and manufacture gear for the vertical world as if it were for us. Most of the manufacturing is handmade and so thousands of finished products or their parts pass through our hands. Over the course of 30 years of SINGING ROCK, many people have taken turns at the machines and computers but some of them have been here almost from the beginning.

We are climbers who work for climbers



Warning:

Activities at height such as climbing, via ferrata, caving, rappelling, ski-touring, rescue, work at height and exploration are dangerous activities, which may lead to severe injury or even death. Thus the following is essential before use: careful reading and understanding of the instructions for use acquaintance with the possibilities and limitations of the product adequate apprenticeship in appropriate techniques and methods of use understanding and acceptance of the risk involved. In case of doubt or problem of understanding, contact SINGING ROCK.

Catalogue CLIMBING WORKBOOK 2024/25

Published by: SINGING ROCK s.r.o. • Copyright © SINGING ROCK s.r.o.

All rights reserved. No part of this publication may be reproduced, distributed, or transmitted in any form or by any means, including photocopying, recording, or other electronic or mechanical methods, without the prior written permission of the publisher, except in the case of brief quotations embodied in critical reviews and certain other noncommercial uses permitted by copyright law. Technical specifications may change without notice.



Address:

Singing Rock
Poniklá 317
512 42 Poniklá
Czech Republic

Contact:

tel.: +420 481 585 007
e-mail: info@singingrock.com
www.singingrock.com

Social:

 [singingrock.page](#)
 [singingrock_official](#)
 [user/sigvideo](#)



CLIMBERS FOR CLIMBERS